

# TM 11-6625-623-45

DEPARTMENT OF THE ARMY TECHNICAL MANUAL

---

GS AND DEPOT MAINTENANCE MANUAL  
**MAINTENANCE KIT, ELECTRONIC  
EQUIPMENT MK-722/URC**



*HEADQUARTERS, DEPARTMENT OF THE ARMY*  
*7 JUNE 1965*



CHANGE }  
No. 4 }

HEADQUARTERS  
DEPARTMENT OF THE ARMY  
WASHINGTON, DC, 31 August 1977

**General Support and Depot Maintenance Manual  
(Including Repair Parts and Special Tool Lists)  
FOR  
MAINTENANCE KIT, ELECTRONIC EQUIPMENT MK-722/URC  
(NSN 5999-00-757-7042)**

TM 11-6625-62345, 7 June 1965, is changed as follows:

1. Title is changed as shown above.
2. Remove and insert pages as indicated below.

*Remove*  
None

*Insert*  
Radiation warning facing inside front cover.

3. File this change sheet in the front of the manual for reference.

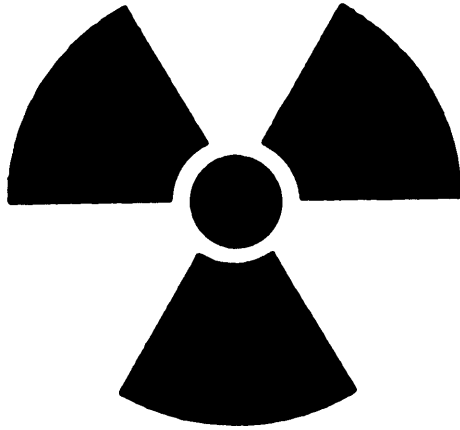

STD-RW-2

Connector            Ra226            24uCi            5935-811-1382

Radiation Hazard Information: The following radiation hazard information must be read and understood by all personnel before operating or repairing Electronic Equipment Maintenance Kit MK-722/URC. Hazardous radioactive materials are present in the above listed component. The components are potentially hazardous when broken. See qualified medical personnel and the local Radiological Protection Officer (RPO) immediately if you are exposed to or cut by broken components. First aid instructions are contained in TB 43-0122, and AR 755-15.

NEVER place radioactive components in your pocket.

Use extreme care NOT to break radioactive components while handling them.

NEVER remove radioactive components from cartons until you are ready to use them.

If any of these components are broken, notify the local RPO immediately. The RPO will survey the immediate area for radiological contamination and will supervise the removal of broken components. The above listed radioactive components *will not* be repaired or disassembled.

Disposal of broken, unserviceable, or unwanted radioactive components will be accomplished in accordance with the instructions in AR 755-15.

By Order of the Secretary of the Army:

BERNARD W. ROGERS  
*General, United States Army*  
*Chief of Staff*

Official:

PAUL T. SMITH  
*Major General, United States Army*  
*The Adjutant General*

Distribution:

To be distributed in accordance with DA Form 12-36A, Direct and General Support maintenance requirements for MK-722/URC.

☆ U.S. GOVERNMENT PRINTING OFFICE: 1977-765010/140

CHANGE }  
NO. 3 }

HEADQUARTERS  
DEPARTMENT OF THE ARMY  
WASHINGTON, DC, 19 August 1974

**General Support and Depot Maintenance Manual  
(Including Repair Parts and Special Tools List)  
MAINTENANCE KIT, ELECTRONIC EQUIPMENT MK-722/URC**

TM 11-6625-623-45, 7 June 1965, is changed as follows:

- 1. Remove and insert pages as indicated below.

<i>Remove</i>	<i>Insert</i>
3 and 4 . . . . .	.3 and 4
21 and 22 . . . . .	.21 and 22
32.3 and 32.4 . . . . .	.32.3 and 32.4

- 2. New or changed material is indicated by a vertical bar.
- 3. File this transmittal sheet in front of the manual for reference.

By Order of the Secretary of the Army:

CREIGHTON W. ABRAMS  
*General, United States Army  
Chief of Staff*

Official:

VERNE L. BOWERS  
*Major General, United States Army  
The Adjutant General*

Distribution:

To be distributed in accordance with DA Form 12-36A, (qty rqr block No. 1081) Direct and General Support maintenance requirements for MK-722/URC.



CHANGE

No. 2

HEADQUARTERS  
DEPARTMENT OF THE ARMY  
WASHINGTON, D. C., 31 July 1967

**GS and Depot Maintenance Manual  
(Including Repair Parts and Special Tools List)  
MAINTENANCE KIT, ELECTRONIC EQUIPMENT MK-722/URC**

TM 11-6625-623-45, 7 June 1965, is changed as follows:

1. Remove and insert pages as indicated below.

Remove-	Insert-
1 through 4 7 and 8 17 and 18 21 and 22 29 through 32 - - - - - 35 and 36 Figure 4-12 (foldout)	1 through 7 and 17 and 21 and 29 through 32.1 through 35 and Figure 4-12

2. File this transmittal sheet in front of the manual for reference.

By Order of the Secretary of the Army:

Official: \_\_\_\_\_

**KENNETH G. WICKHAM,**  
*Major General, United States Army,  
The Adjutant General.*

**HAROLD K. JOHNSON,**  
*General, United States Army,  
Chief of Staff.*

***DISTRIBUTION :***

To be distributed in accordance with DA Form 12-36 (Unclass) requirements for Direct and General Support Maintenance applicable to the OV-1A; OV-1B; OV-1C; U-1A; U-6A; U-8F; U-10A; CH-21B; CH-21C; CH-34C; CH-37B; CH-47A; UH-1B and UH-1D aircraft.

**MAINTENANCE KIT, ELECTRONIC EQUIPMENT MK-722/URC**

	Paragraph	Page
CHAPTER 1	FUNCTIONING OF MAINTENANCE KIT, ELECTRONIC EQUIPMENT MK-722/URC	
Section I.	General	
	Scope of manual . . . . .	1-1 3
	Index of publications . . . . .	1-2 3
	Reporting of equipment manual improvements . . . . .	1-3 3
II.	Functional test set block diagram analysis	
	Introduction . . . . .	1-4 3
	Block diagram analysis . . . . .	1-5 3
III.	Circuit analysis	
	Input power circuit . . . . .	1-6 4
	Rectifier circuit . . . . .	1-7 5
	Voltage regulator circuit . . . . .	1-8 5
	Comparison circuits . . . . .	1-9 5
	Dummy microphone circuit . . . . .	1-10 6
	Miscellaneous items . . . . .	1-11 6
CHAPTER 2	TROUBLESHOOTING	
Section I.	General troubleshooting techniques	
	General instructions . . . . .	2-1 7
	Organization of troubleshooting procedures . . . . .	2-2 7
	Test equipment required . . . . .	2-3 7
II.	Troubleshooting	
	Localizing troubles . . . . .	2-4 8
	Troubleshooting chart . . . . .	2-5 9
	Dc resistance of transformer and coil . . . . .	2-6 13
CHAPTER 3	REPAIRS AND CALIBRATION	
Section I.	Repairs	
	General parts replacement techniques . . . . .	3-1 15
	Replacement data . . . . .	3-2 15
II.	Calibration	
	Test equipment required for calibration . . . . .	3-3 16
	Calibration procedure . . . . .	3-4 16
CHAPTER 4	GENERAL SUPPORT TESTING PROCEDURES	
	General . . . . .	4-1 25
	Test equipment required . . . . .	4-2 25
	Modification work orders . . . . .	4-3 25
	Physical tests and inspections . . . . .	4-4 27
	Voltage and resistance measurements . . . . .	4-5 29
	Test data summary . . . . .	4-6 31
CHAPTER 5	DEPOT OVERHAUL STANDARDS, MAINTENANCE KIT, ELECTRONIC EQUIPMENT, MK-722/URC	
	Applicability of depot overhaul standards . . . . .	5-1
	Applicable references . . . . .	5-2
	Test facilities required . . . . .	5-3
	General test requirements . . . . .	5-4
	Test of voltage divider TS-1954/URC (2 to 8 mc) . . . . .	5-5
	Test of voltage divider TS-1955/CRC (8 to 30 mc) . . . . .	5-6
	Test of detector, radio frequency DT-278/URC . . . . .	5-7
	Test of extender, module MX-4892/URC . . . . .	5-8
	Test of dummy load, electrical DA-340/URC . . . . .	5-9
	Test of attenuator, fixed CN-1066/URC . . . . .	5-10
	Test of test probe No. 1 . . . . .	5-11
APPENDIX I.	REFERENCES . . . . .	



# CHAPTER 1

## FUNCTIONING OF MAINTENANCE KIT, ELECTRONIC EQUIPMENT MK-722/URC

---

### Section I. GENERAL

#### 1-1. Scope of Manual

a. This manual covers general support and depot maintenance for Maintenance Kit, Electronic Equipment MK-722/URC. It includes instructions appropriate to general support and depot maintenance for troubleshooting, testing, aligning, and repairing the equipment, and replacing maintenance parts. It also lists tools, materials, and test equipment for general support and depot maintenance.

b. The purpose, operation, and interoperation of the various circuits (electrical and electro-mechanical) in the MK-722/URC are explained in paragraph 1-4 through 1-11. Familiarity with the equipment, how it works, and why it works the way it does are valuable tools in troubleshooting the equipment rapidly and effectively.

c. The complete technical manual for this equipment includes TM 11-6625-623-12.

#### NOTE

For applicable forms and records, see paragraph 1-3 TM 11-6625-623-12.

#### 1.2. Indexes of Publications

a. Refer to the latest issue of DA Pam 310-4 to determine whether there are new additions, changes or additional publications pertaining to the equipment.

b. Refer to the latest issue of DA Pam 310-7 to determine whether there are modification work orders (MWO'S) pertaining to the equipment.

#### 1-3. Reporting of Equipment Manual Improvements

Report of errors, omissions, and recommendations for improving this manual by the individual user is encouraged. Reports should be submitted on DA Form 2028 (Recommended Changes to Publications and Blank Forms) and forwarded direct to Commander, US Army Electronics Command, ATTN: AMSEL-MA-A, Fort Monmouth, NJ 07703.

### Section II. FUNCTIONAL TEST SET BLOCK DIAGRAM ANALYSIS

#### 1-4. Introduction

The function test set (main component of the MK-722/URC) is used in the testing and troubleshooting of the receiver-transmitter (a component of Radio Set AN/ARC-102). The function test set acts as an accurate voltage comparator which is used to set critical voltages in the receiver-transmitter. It is also used as a variable voltage source with three difference source impedances for test purposes.

#### 1-5. Block Diagram Analysis

(fig. 1-1)

Block diagram analysis of the function test set is covered in *a* through *h* below. For complete circuit details, refer to the overall schematic diagram (fig. 4-11).

a. *Input Power Circuit.* The 115-volt, 400-cycles-per-second (cps) input power is applied to the function test set from an external source. The input power is applied through

isolating transformer T1 to the rectifier circuit consisting of diode CR1 capacitor C1, and inductor L1.

b. *Rectifier Circuit.* The rectifier circuit takes the 115-volt, 400-cps input power, and rectifies and filters it to provide a direct current (dc) input to the calibrated dc regulator circuit consisting of Zener diodes CR3 and CR4.

c. *Dc Regulator circuit.* The filtered dc output of the rectifier circuit is applied to the dc regulator circuit which provides a constant level dc reference voltage to FUNCTION METER M1.

d. *FUNCTION SELECTOR Switch S1A.* FUNCTION SELECTOR Switch S1A connects the proper reference voltage to FUNCTION METER M1.

e. *Input Jacks.* Input jacks J1-KC STAB, J3-KC STAB, J4-KC STAB, J2-IF TRANS, and J2-FREQ DIVIDER are used to bring test signals from the receiver-transmitter to FUNCTION SELECTOR switch S1B.

f. *FUNCTION SELECTOR Switch S1B.* FUNCTION SELECTOR Switch S1B connects the proper input jack to FUNCTION METER M1.

g. *FUNCTION METER M1.* FUNCTION METER M1 gives indications of differences between the reference voltage and the signal being checked.

h. *Dummy Microphone Circuit.* The dummy microphone circuit is used to connect audio tone inputs to the receiver-transmitter.

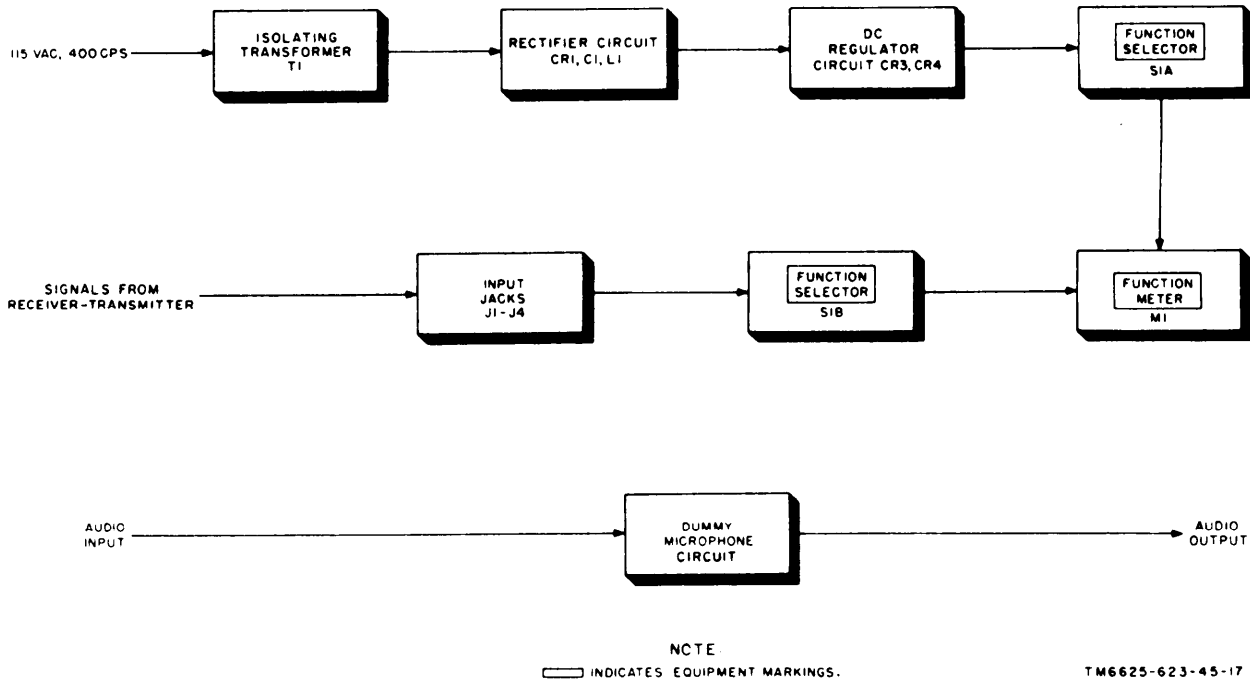

Figure 1-1. Function test set, block diagram.

### Section III. CIRCUIT ANALYSIS

#### 1-6. Input Power Circuit

(fig. 4-11)

The 115-volt, 400-cps voltage is applied through the power cable and connector J12,

power switch S3A, and 1/4-ampere fuse F1 to the primary of isolating transformer T1. One pin of the secondary of transformer T1 is grounded. The other pin provides alternating current (ac) voltage to two branches. One

## CHAPTER 2

### TROUBLESHOOTING

---

#### Section I. GENERAL TROUBLESHOOTING TECHNIQUES

**Warning:** When servicing the function test set, be careful when working with the 115-volt, 100-CPS, ac line voltage. Disconnect the power cable from the power source when making internal resistance measurements.

#### 2-1. General Instructions

Troubleshooting at general support and depot maintenance level includes all the techniques outlined for organizational maintenance and any special or additional techniques required to isolate a defective part. The general support and depot maintenance procedures are not complete in themselves but supplement the maintenance and repair procedures described in TM 11-6625-623-12. The systematic troubleshooting procedure, which begins with the maintenance and repair procedures that can be performed at an organizational level, must be completed by additional localizing and isolating techniques.

#### 2-2. Organization of Troubleshooting Procedures

*a. General.* The first procedure in servicing a defective function test set is to localize the fault. Localizing means tracing the fault to a circuit. The second procedure is to isolate the fault. Isolation means tracing the fault to a defective part responsible for the abnormal condition.

*b. Localization.* The first procedure in tracing trouble is to locate the circuit at fault by the following methods:

- (1) *Visual inspection.* The purpose of visual inspection is to locate faults without performing tests or measurements. Some faults, such as burned-out resistors, can be located by sight. The trouble, therefore, can be immediately isolated.

- (2) *Measurement chart.* If no symptoms are known, perform the checks given in the measurement chart (para 2-4).
- (3) *Troubleshooting chart.* The symptoms and procedures listed in the troubleshooting chart (para 2-5) will aid in isolating the trouble to a specific circuit or component.
- (4) *Intermittent troubles.* In all test, the possibility of intermittent troubles should not be overlooked. If present, this type of trouble often may be made to appear by tapping or jarring the equipment. Check the wiring and cable connections.

*c. Isolation.* Once the faulty circuit or section of the circuit is located, the faulty component is located by voltage and/or resistance measurements. Use the voltage and resistance diagram (fig. 2-4) to find normal readings, and compare them with readings taken. Use resistor and capacitor color codes (fig. 4-9 and 4-10) to find the value of components.

#### 2-3. Test Equipment Required

The following test equipment is required for troubleshooting the function test set:

- a. Multimeter ME-26B/U (multimeter), TM 11-6625-200-12, or equivalent.
- b. Voltmeter, Electronic AN/USM-98 (differential voltmeter), TM 11-6625-438-10, or equivalent.
- c. Power Supply PP-351/U (dc power supply), TM 11-5121, or equivalent.

*Note.* Voltage supply must be adjustable to two-decimal place accuracy.

Section II. TROUBLESHOOTING

2-4. Localizing Troubles

a. *When to Check.* When any of the following conditions exist, perform the checks indicated and clear the troubles before returning to operation:

- (1) The nature of the abnormal symptoms is not known.
- (2) The abnormal symptoms reported by the operator indicate possible reference voltage troubles.

b. *Conditions for Test.*

- (1) When making resistance measurements, disconnect the power cable from the 115-volt, 400-cps, ac power source.
- (2) Remove the rear cover to reach the inside components. Refer to figures 2-1, 2-2, and 2-3 for parts location.
- (3) Set the function test set controls as indicated in the tests.

c. *Measurements Chart.* Make the voltage and resistance measurements indicated in the following chart. If abnormal results are obtained, refer to the troubleshooting chart (para 2-5) for additional isolating procedures.

Step No.	Procedure	Normal indication
1	Set the FUNCTION SELECTOR switch to TGC OVERRIDE position. Measure resistance between J2-IF TRANS jack J9 and J2-FREQ DIVIDER jack J11 with TGC & CAPTURE RANGE R3 potentiometer at clockwise and counterclockwise stops.	Circuits should measure 600 ohms $\pm$ 120 with R3 at clockwise stop and 100 ohms $\pm$ 20 with R3 at counterclockwise stop.
2	Set the FUNCTION SELECTOR switch to TGC OVERRIDE position. Set TGC & CAPTURE RANGE R3 potentiometer to the clockwise stop. Measure resistance between J2-IF TRANS jack J9 and GRND J11.	Circuits should measure 100 ohms $\pm$ 20.
3	Set the FUNCTION SELECTOR switch to 70K-5 CAPTURE RANGE position. Set TGC & CAPTURE RANGE R3 potentiometer to the counterclockwise stop. Measure the resistance between J3-KC STAB jack J8 and J2-FREQ DIVIDER jack J11.	Circuit should measure 10,000 ohms $\pm$ 1,500.
4	Set the FUNCTION SELECTOR switch to 70K-3 CAPTURE RANGE position. Set TGC & CAPTURE RANGE R3 potentiometer to the counterclockwise stop. Measure the resistance between J1-KC stab jack J7 and J2-FREQ DIVIDER jack J11.	Circuit should measure 470,000 $\pm$ 70,000 ohms.
5	Set the FUNCTION SELECTOR switch to the SET LEVEL position. Measure resistance between CALIBRATE WITH 10.000V R4 jack J1 (brown) and GRND jack J13 with OFFSET ADJUST R2 potentiometer at clockwise and counterclockwise stops.	Circuit should measure 0 ohm at clockwise stop and 50 ohms $\pm$ 10 at counterclockwise stop.
6	Measure the resistance between NO. 1 and NO. 2 AUDIO IN jacks J5 and J6.	Circuit should measure 164 ohms $\pm$ 25.
7	Measure the resistance between AUDIO OUT jack J4 and GRND jack J13.	Circuit should measure 82 ohms $\pm$ 12.
8	Measure the resistance between AUDIO OUT jack J4 and TEST POINT jack J3.	Circuit should measure 0 ohm.

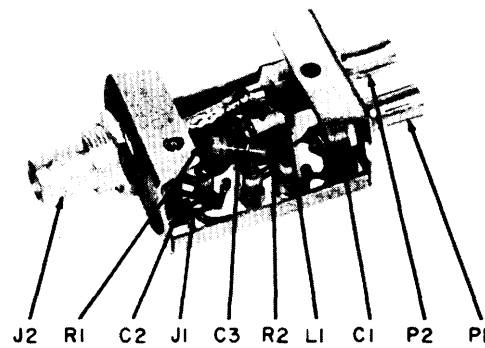

TM6625-623-45-6

Figure 3-4. Rf translator load, parts location.

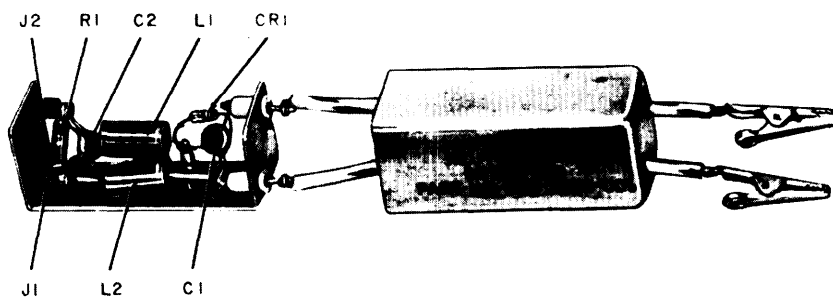

TM6625-623-45-2

Figure 3-5. Neutralizing detector, parts location.

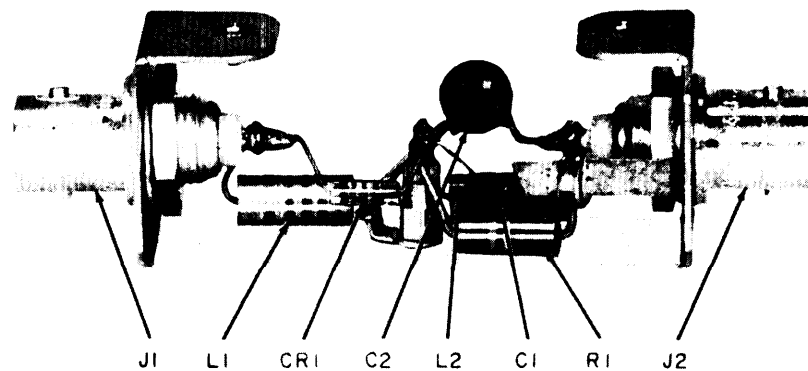

TM6625-623-45-21

Figure 3-6. Detector, 2- to 30-mc, parts location.

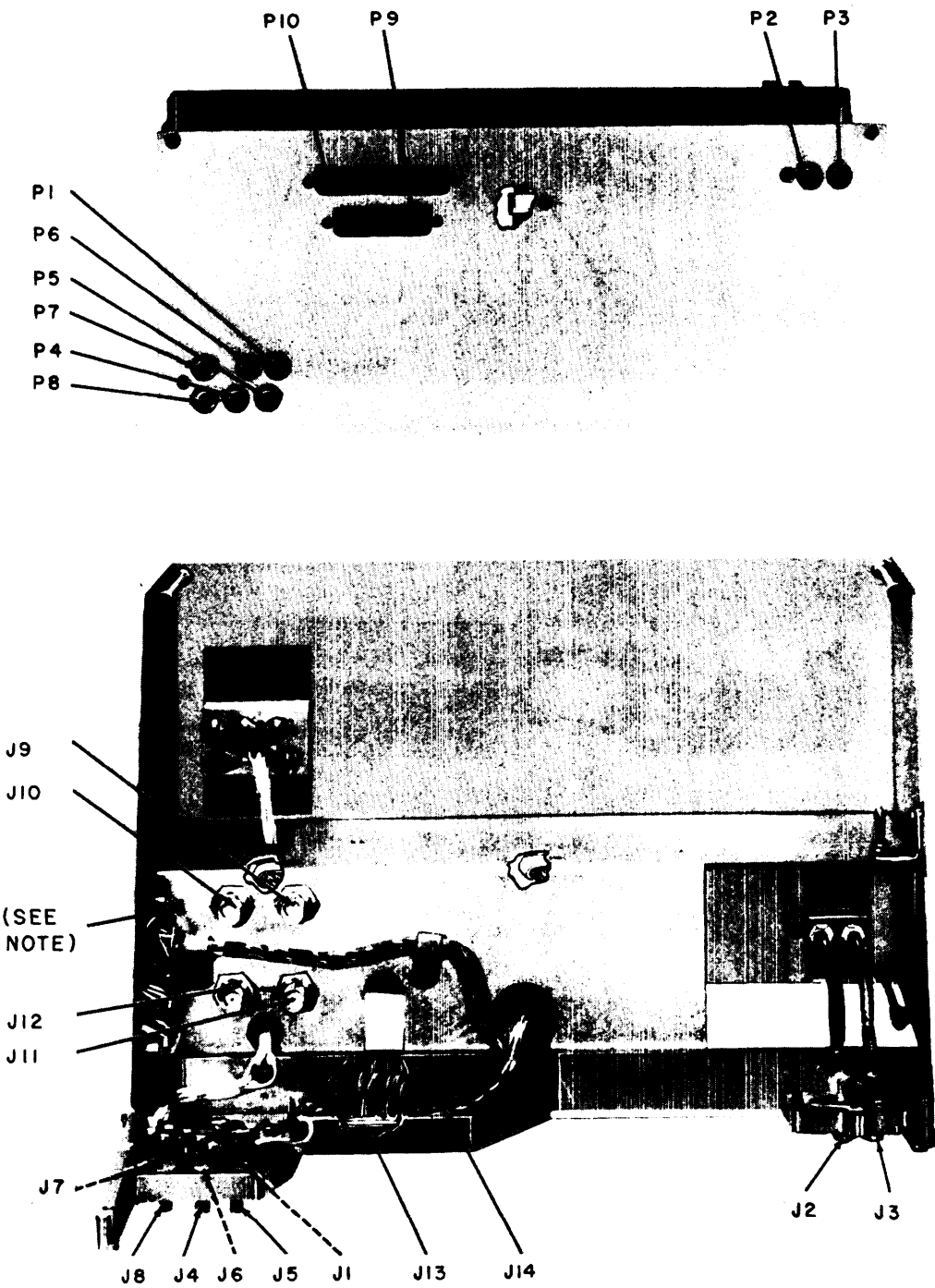

TM6625-623-45-1

Figure 3-7. Rf translator module extender, parts location.

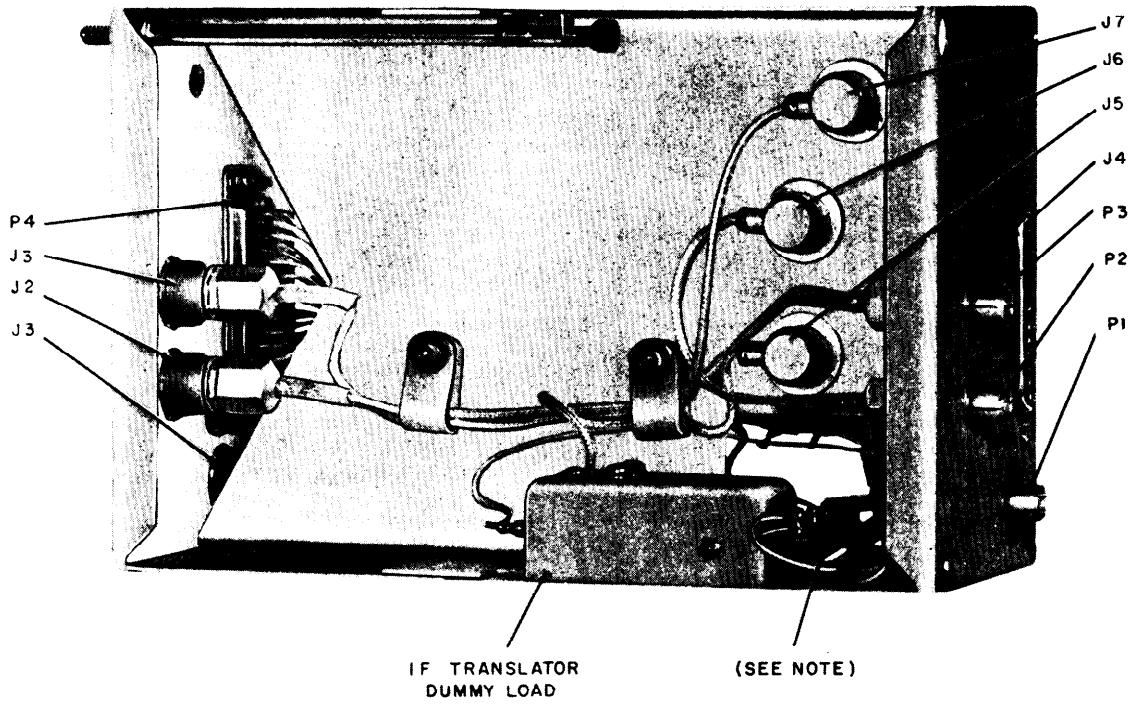

NOTE:  
TP4, TP5, TP7 THRU TPI2, TPI4, TPI7, TPI8, TPI9, AND TP20.

TM6625-623-45-20

Figure 3-12. If translator module extender, parts location.

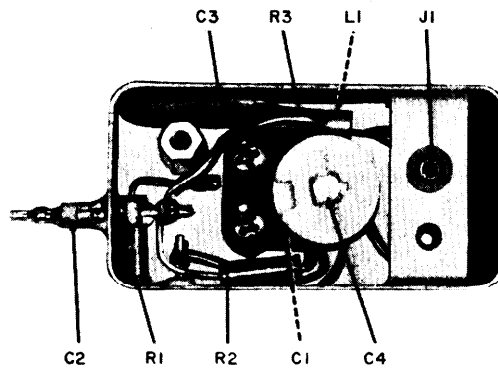

TM6625-623-45-22

Figure 3-13. If translator dummy load, parts location.

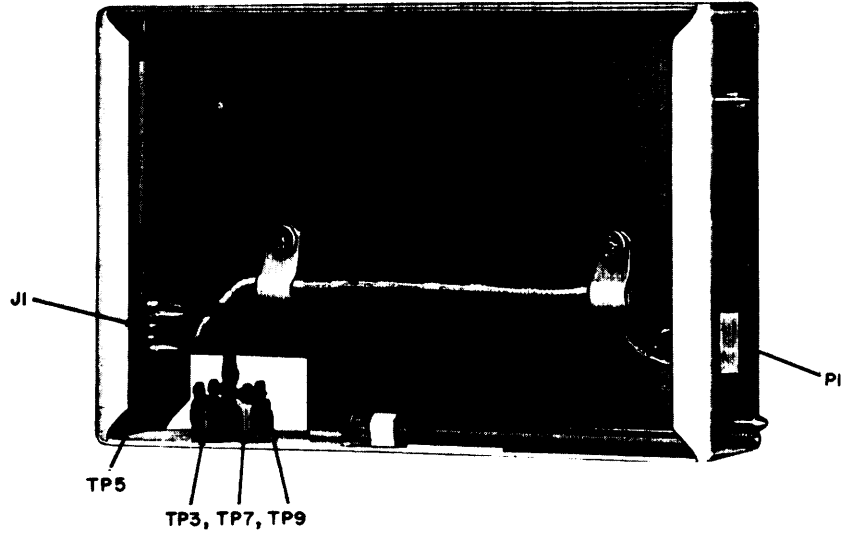

TM6625-623-45-13

Figure 3-14. Electronic control amplifier (ampl) module extender, parts location.

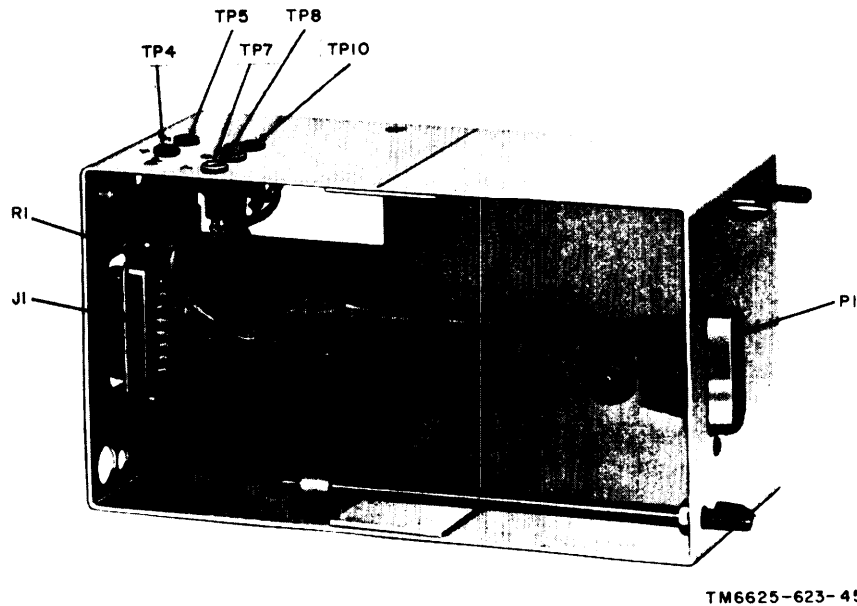

TM6625-623-45-12

Figure 3-15. Low-voltage power supply module extender, parts location.



#### 4-5. Voltage and Resistance Measurements

##### a. Test Equipment and Materials.

- (1) Multimeter ME-26B/U (multimeter) or equivalent.
- (2) Voltmeter, Electronic AN/USM-98 (differential voltmeter) or equivalent.
- (3) Power Supply PP-351/U (variable dc voltage supply, 0 to 20 volts, 1 milliampere (ma) maximum) or equivalent.

##### b. Test Connections and Conditions.

- (1) Make test connections as specified in *Test procedure* column of *c* below and illustrated in figure 4-1.
- (2) Resistance checks are made with no power applied to the function test set.

*Note:* For parts location, refer to figures 2-1, 2-2, and 2-3.

##### c. Procedure.

Step No.	Control setting		Test procedure	Performance standard
	Test equipment	Equipment under test		
1	a. FUNCTION switch: OHMS. b. RANGE switch: RX10.	FUNCTION SELECTOR switch: TGC OVERRIDE.	Measure the resistance between J2-IF TRANS jack J9 and J2-FREQ DIVIDER jack 11 with TGC & CAPTURE RANGE R3 potentiometer at clockwise and counterclockwise stop.	Circuit should measure 600 ohms $\pm$ 120 with R3 at clockwise stop and 100 ohms $\pm$ 20 at counterclockwise stop.
2	Same as step 1.	a. FUNCTION SELECTOR switch: TGC OVERRIDE, b. TGC & CAPTURE RANGE R3 potentiometer: clockwise stop.	Measure the resistance between J2-IF TRANS jack J9 and GRND jack J13.	Circuit should measure 100 ohms $\pm$ 20.
3	a. FUNCTION switch: OHMS. b. RANGE switch: RX1K.	a. FUNCTION SELECTOR switch: 70K-5 CAPTURE RANGE. b. TGC & CAPTURE RANGE R3 potentiometer: counterclockwise stop.	Measure the resistance between J3-KC STAB jack J8 and J2-FREQ DIVIDER jack J11.	Circuit should measure 10,000 ohms $\pm$ 1,500.
4	a. FUNCTION switch: OHMS. b. RANGE switch: RX100K.	a. FUNCTION SELECTOR switch: 70 K-3 CAPTURE RANGE, b. TGC & CAPTURE RANGE R3 potentiometer: counterclockwise stop.	Measure the resistance between J1-KC STAB jack J7 and J2-FREQ DIVIDER jack J11.	Circuit should measure 470,000 $\pm$ 70,000 ohms.
5	a. FUNCTION switch: OHMS. b. RANGE switch: RX1.	a. FUNCTION SELECTOR switch: SET LEVEL.	Measure the resistance between CALIBRATE WITH 10.000V R4 jack J13 with OFF-SET. ADJUST R2 potentiometer at clockwise and counterclockwise stops.	Circuit should measure 0 ohm at clockwise stop and 50 ohms $\pm$ 10 at counterclockwise stop.

Step No.	Control setting		Test procedure	Performance standard
	Test equipment	Equipment under test		
6	a. FUNCTION switch: OHMS. b. RANGE switch: RX10.	Controls and switches may be in any position.	Measure the resistance between NO. 1 and NO. 2 AUDIO IN jacks J5 and J6.	Circuit should measure 164 ohms $\pm 25$ .
7	Same as step 6.	Same as step 6.	Measure the resistance between AUDIO OUT jack J4 and GRND jack J13.	Circuit should measure 82 ohms $\pm 12$ .
8	a. FUNCTION switch: OHMS. b. RANGE switch: RX1.	Same as step 6.	Measure the resistance between AUDIO OUT jack J4 and TEST POINT jack J3.	Circuit should measure 0 ohm.
9	a. FUNCTION switch: OHMS. b. RANGE switch: RX1M.	Same as step 6.	Measure the resistance from NO. 1 AUDIO IN jack J5 to GRND jack J13.	Capacitor C2 charges until resistance to ground is infinite.
10	a. FUNCTION switch: +. b. RANGE switch: 300V.	a. FUNCTION SELECTOR switch: TGC OVERRIDE. b. Ac power switch ON.	Measure the voltage to ground across the series Zener diodes CR3 and CR4.	Circuit should measure 103 volts dc $\pm 5$ .
11	a. FUNCTION switch: +. b. RANGE switch: 100V.	a. FUNCTION SELECTOR switch: TGC OVERRIDE. b. LEVEL SET R1 potentiometer: counter-clockwise stop. c. Ac power switch: ON.	Measure the voltage to ground at the center arm of R1.	Circuit should measure 75 volts dc $\pm 10$ .
12	Same as 11.	a. FUNCTION SELECTOR switch: SET LEVEL. b. Ac power switch: ON.	Adjust LEVEL SET R1 potentiometer until the FUNCTION METER of the function test set reads + 10. Measure the voltage to ground at the center arm of R1.	Circuit should measure 90 volts dc $\pm 5$ .
13	Set the differential voltmeter to measure 10 volts dc.	a. FUNCTION SELECTOR switch. 70K-3 VFO BIAS. b. Ac power switch: ON.	Connect the differential voltmeter between the CALIBRATE WITH 10.000V R4 test points.	Differential voltmeter should read 10.000 volts dc $\pm .001$ .

Step No.	Control setting		Test procedure	Performance standard
	Test equipment	Equipment under test		
14	Set the differential voltmeter to read 20 volts dc.	<i>a.</i> FUNCTION SELECTOR switch: 10KC CONTROL BIAS (+20V). <i>b.</i> Ac power switch: ON.	Apply a dc voltage of approximately 20 volts between J4-KC STAB jack J10 and ground. Vary the dc voltage for a null indication on the FUNCTION METER. Measure the applied dc voltage with the differential voltmeter.	Differential voltmeter should read 19.930 volts dc.
15	Set the differential voltmeter to read 18 volts.	<i>a.</i> FUNCTION SELECTOR switch: +18V. <i>b.</i> Ac power switch: ON.	Apply a dc voltage of approximately 18 volts between J2-FREQ DIVIDER Jack J11 and ground. Vary the voltage for an exact FUNCTION METER null with the X10 METER SENSITIVITY switch depressed. Measure the applied dc voltage with the differential voltmeter.	Differential voltmeter should read 18.000 volts dc $\pm 0.036$ .

**4-6. Test Data Summary**

Maintenance personnel may find it convenient to arrange the checklists in a manner similar to that below. The data included in the checklists may then be used as a check against the test results the next time the tests are performed.

**VOLTAGE AND RESISTANCE MEASUREMENTS**

*Note:* The numbers in the *Step No.* column below are references to the *Step No.* column in paragraph 4-5c.

Step No.	Indication
1	600 ohms $\pm 120$ at clockwise stop. 100 ohms $\pm 20$ at counterclockwise stop.

Step No.	Indication
2	100 ohms $\pm 20$ .
3	10,000 ohms $\pm 1,500$ .
4	470,000 $\pm 70,000$ ohms.
5	0 ohm at clockwise stop. 50 ohms $\pm 10$ at counterclockwise stop.
6	164 ohms $\pm 25$ .
7	82 ohms $\pm 12$ .
8	0 ohm.
9	Capacitor C2 charges until resistance to ground is infinite.
10	103 volts dc $\pm 5$ .
11	75 volts dc $\pm 10$ .
12	90 volts dc $\pm 5$ .
13	10.000 volts dc $\pm 0.001$ .
14	19.930 volts dc.
15	18.000 volts dc $\pm 0.036$ .

CHAPTER 5

DEPOT OVERHAUL STANDARDS , MAINTENANCE KIT,  
ELECTRONIC EQUIPMENT MK-722/URC

---

5-1. Applicability of Depot Overhaul Standards

The tests outlined in this chapter are designed to measure performance capability of repaired equipment. Equipment that meets the minimum standards stated in the tests will furnish satisfactory operation, equivalent to that of new equipment.

5-2. Applicable References

a. Repair Standards. Applicable procedures of the depots performing this test and the general standards for repaired electronic equipment given in TB SIG 355-1, TB SIG 355-2, and TB SIG 355-3 form a part of the requirements for testing this equipment.

b. Technical Publications. The following Technical Publications are applicable to this equipment:

<u>Title</u>	<u>Number</u>	<u>Date</u>
DS, GS, and Depot Maintenance Manual; Radio Set AN/ARC-102	TM 11-5821-248-35	March 3, 1966
Organizational Maintenance Manual (including repair parts and special tool lists); Maintenance Kit, Electronic Equipment MK-722/URC	TM 11-6625-623-12	Dec. 10, 1964
DS and Depot Maintenance Manual (including repair parts and special tool lists); Maintenance Kit, Electronic Equipment MK-722/URC	TM 11-6625-623-45	June 7, 1965

c. Modification Work Orders. Perform all applicable Modification Work Orders pertaining to this equipment before making the tests specified. DA PAM 310-7 lists all available MWO'S.

5-3. Test Facilities Required

The following equipments, or suitable equivalents, will be employed in determining compliance with the requirements of this Specific Standard.

*a. Test Equipment.*

Equipment	Stock No.	Quantity required	Applicable literature
Multimeter ME-26B/U	6625-542-6407	1	TM 11-6625-200-12
Voltmeter, Meter ME-30A/U	6625-669-0742	1	TM 11-6625-320-12
Resistance Bridge ZM-4B/U	6625-324-9422	1	TM 11-2019, TM 11-6625-249-12P
Analyzer ZM-3/U	6625-229-1060	1	TM 11-5043-12, TM 11-6625-241-20P
Voltmeter, Electronic AN/URM-145	6625-973-3986	1	TM 11-6625-524-14
Voltmeter, Electronic AN/USM-98	6625-753-2115	1	TM 11-6625-438-10
Signal Generator AN/GRM-50	6625-819-0472	1	TM 11-6625-73-15
Power Supply PP-351/U	6130-565-0706	1	TM 11-5121

*b. Additional Equipment.*

Equipment	Stock No.	Quantity required	Remarks
Impedance pad, 6 db, 50 ohms	6625-521-6787	1	
Cable, RF CG-2727/U	6625-964-2630	1	P/O AN/ARC-102
Adapter, Connector P/N 1645 Pomona Elec	5935-709-5709	1	P/O AN/ARC-102, used with ME-30A/U.
Connector RF UG-274B/U	5935-683-7892	1	P/O AN/ARC-102
Connector RF UG-88E/U	5935-823-0487	1	Fabricate 4.5 in. cable.
Connector-Hood 1PC2275 Collins P/N 357-9475-00		1	Fabricate 4.5 in. cable.
Cable, RF RG-58C/U	6145-542-6092	1	Fabricate 4.5 in. cable.
Connector RF UG-491B/U	5935-681-5013	1	P/O AN/ARC-102, used with AN/GRM-50.
Connector, RF UG-1051/U	5935-685-9913	1	Fabricate 4.5 in. cable.

Note. Fabrication of an rf cable using cable, RF RG-58C/U terminated with connectors UG-88E/U and UG-1051/U is required. Connector-Hood 1PC2275 is used to strengthen the fabricated cable and is connected to the UG-1051/U. If the connector-hood is not available, cable shield must be connected to the UG-1051/U.

#### 5-4. General Test Requirements

Depot overhauls standards consist of performance of the tests indicated in paragraphs 4-4, 4-5, and 4-6 and the following tests. The following tests consist of signal level measurements and continuity checks. Paragraphs 4-4, 4-5, and 4-6 cover tests of the TS-1956/URC (fig. 4-11), the function test set.

#### 5-5. Test of Voltage Divider TS-1954/URC (2 to 8 mc capacity divider)

(fig. 3-2 and 4-3)

a. Set the output frequency of the AN/GRM-50 (signal generator) to 5 mc.

b. Connect the 6-db pad between the signal generator and the ME-30A/U.

c. Set the signal generator output for a 5 mc, .33 volt output.

d. Connect the input terminal of the TS-1954/URC to the output of the 6-db pad and connect the ME-30A/U to the output terminal of the TS-1954/URC.

e. ME-30A/U should indicate 0.01 volt  $\pm 10\%$  (0.009 to 0.011 volt).

#### 5-6. Test of Voltage Divider TS-1955/URC (8 to 30 mc capacity divider)

(fig. 3-3 and 4-4)

a. Set the output frequency of the signal generator for 19 mc.

b. Connect the 6-db pad between the signal generator and the AN/URM-145.

c. Set the signal generator output for a 19 mc, .35 volt output.

d. Connect the input terminal of the TS-1955/URC to the output of the 6-db pad and connect the AN/URM-145 to the output terminal of the TS-1955/URC.

e. AN/URM-145 should indicate 0.01 volts  $\pm 0.001$ .

#### 5-7. Test of Detector, Radio Frequency DT/278/URC (Neutralizing Detector)

(fig. 3-5 and 4-6)

a. Set the output frequency of the signal

generator to 500 kc.

b. Connect the 6-db pad between the signal generator and the ME-30A/U.

c. Set the signal generator for a 500 kc, 1 volt output.

d. Disconnect the ME-30A/U.

e. Connect the DT-278/URC red lead to the common terminal of the 6-db pad and the gray lead to the positive terminal of the 6-db pad.

f. Connect the ME-26B/U between the red and gray tip jacks of the DT-278/URC (red tipjack is common). The ME-26B/URC should indicate no less than 1 volt dc.

#### 5-8. Test of Extender, Module MX-4892/URC (If Translator Module Extender)

(fig. 3-12, 3-13, 4-8 and 4-12)

a. Set the output frequency of the signal generator to 500 kc.

b. Connect the 6-db pad between the signal generator and the ME-30A/U; use the CG-2727/U to connect the 6-db pad to the ME-30A/U.

c. Adjust the signal generator for an output of 0.07 volt.

d. Disconnect the ME-30A/U from the CG-2727/U and connect the CG-2727/U to the MX-4892/URC RF LOAD BNC connector.

e. Connect the ME-30A/U between the MX-4892/URC blue tipjack and the frame.

f. Adjust the capacitor on the side of the MX-4892/URC to an indication on the ME-30A/U of a peak of 0.0055 volt  $\pm 0.0005$ .

g. Disconnect the MX-4892/URC from test setup and test continuity of remaining circuits (fig. 4-12).

#### 5-9. Test of Dummy Load, Electrical DA-340/URC (Rf Translator Load)

(fig. 3-4 and 4-5)

a. Set the output frequency of the signal generator to 2 mc.

b. Connect the AN/URM-145 to the signal generator output with the UG-274B/U connector.

*c.* Set the signal generator for a 2mc, 3 volts, output.

*d.* Connect the UG-274B/U connector to the DA-340/URC connector associated with the blue tipjack using the 4-12-inch fabricated cable.

*e.* Check that the AN/URM-145 indicates not less than 2.90 volts.

*f.* Set the frequency of the signal generator to 30 mc and disconnect the DA-340/URC from the UG-274B/U.

*g.* Set the signal generator output level to 3 volts.

*h.* Connect the DA-340/URC to the UG-274 B/U as indicated in *d* above.

*i.* The AN/URM-145 shall indicate 2.2 volts  $\pm 0.11$ .

*j.* Check that resistance between J1 and P1 and between J2 and P2 is less than one (1) ohm.

**5-10. Test of Attenuator, Fixed CN-1066/URC (Generator Load)**  
(fig.m 3-1 and 4-2)

*a.* Connect the ZM-4B/U between center conductors of the CN-1066/URC BNC connectors.

*b.* The ZM-4B/U shall indicate 50 ohms  $\pm 5$ ; center conductors shall not be shorted to outer conductor or case.

**5-11. Test of Test Probe No. 1**  
(TM 11-6625-623-12, fig. 1-6)

*a.* Connect the ZM-3/U between center conductors (tip probe to center of BNC connector).

*b.* The ZM-3/U shall indicate 100 mmf  $\pm 10$  mmf.

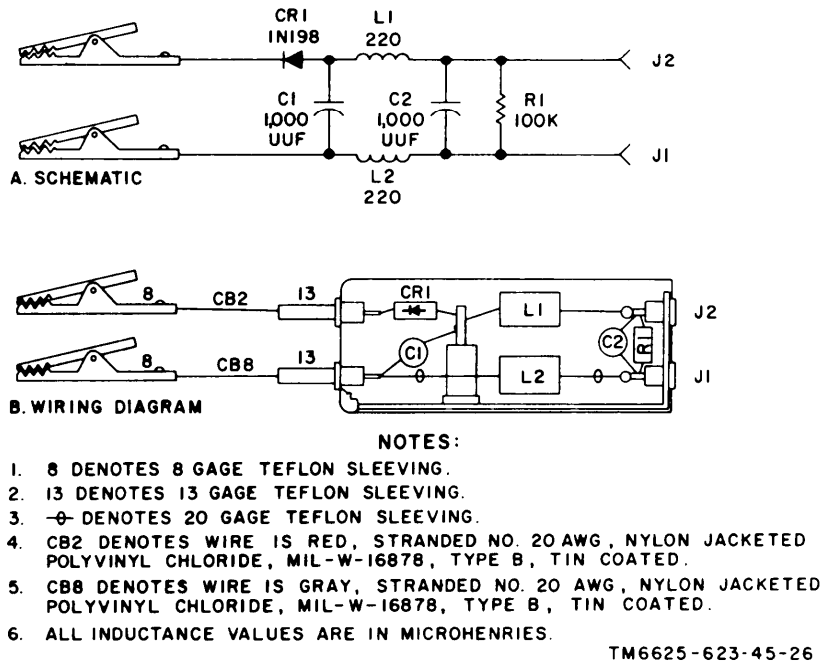

Figure 4-6. Neutralizing detector, schematic and wiring diagram.

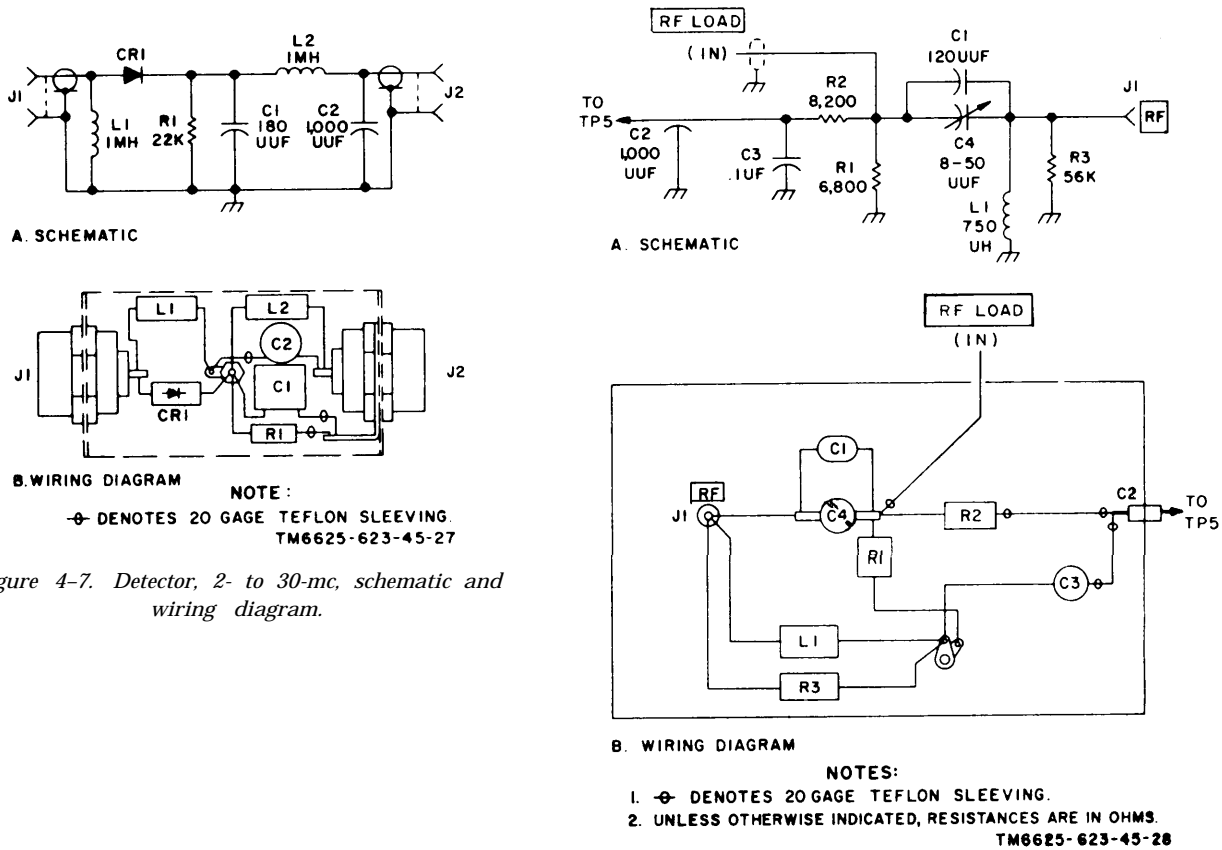
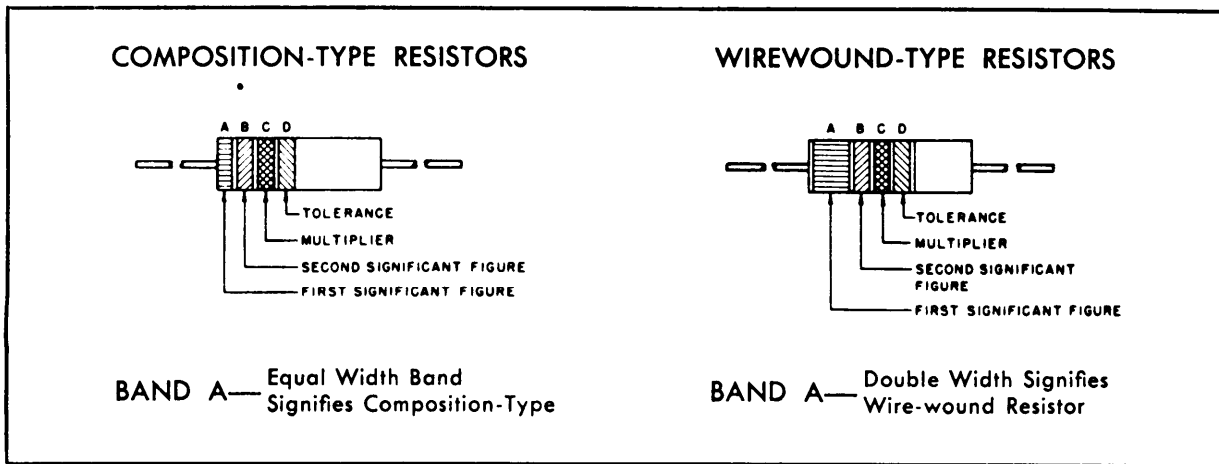

Figure 4-7. Detector, 2- to 30-mc, schematic and wiring diagram.

Figure 4-8. If translator dummy load, schematic and wiring diagram.



COLOR CODE MARKING FOR MILITARY STANDARD RESISTORS



COLOR CODE TABLE

BAND A		BAND B		BAND C		BAND D*	
COLOR	FIRST SIGNIFICANT FIGURE	COLOR	SECOND SIGNIFICANT FIGURE	COLOR	MULTIPLIER	COLOR	RESISTANCE TOLERANCE (PERCENT)
BLACK	0	BLACK	0	BLACK	1		
BROWN	1	BROWN	1	BROWN	10		
RED	2	RED	2	RED	100		
ORANGE	3	ORANGE	3	ORANGE	1,000		
YELLOW	4	YELLOW	4	YELLOW	10,000	SILVER	± 10
GREEN	5	GREEN	5	GREEN	100,000	GOLD	± 5
BLUE	6	BLUE	6	BLUE	1,000,000		
PURPLE (VIOLET)	7	PURPLE (VIOLET)	7				
GRAY	8	GRAY	8	SILVER	0.01		
WHITE	9	WHITE	9	GOLD	0.1		

EXAMPLES OF COLOR CODING

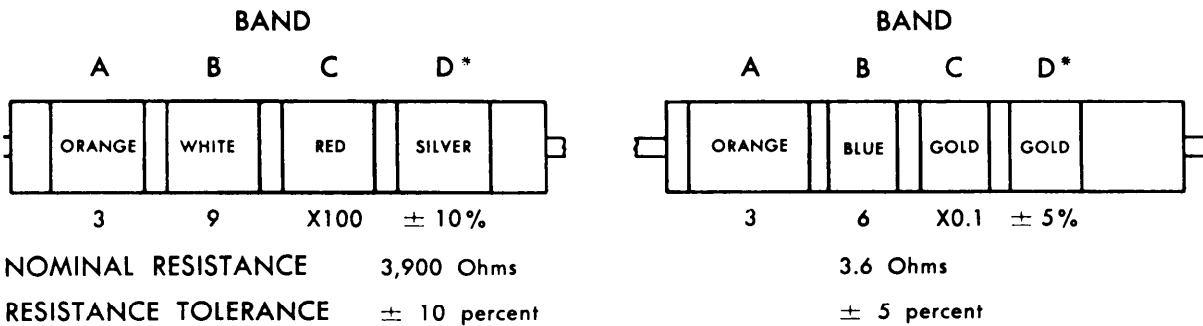

\*If Band D is omitted, the resistor tolerance is ± 20%, and the resistor is not Mil-Std.

STD-R2

Figure 4-9. Color code marking for MIL-STD resistors.

*Figure 4-12. Module extenders, schematic diagram.*

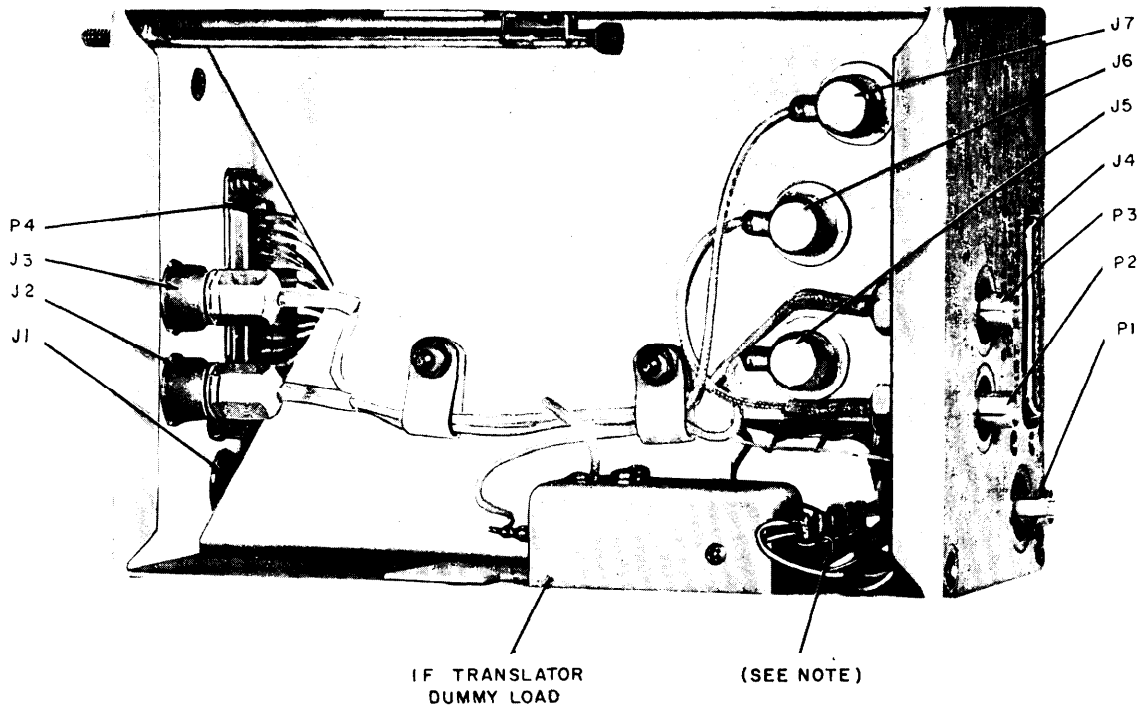

NOTE:  
TP4, TP5, TP7 THRU TP12, TP14, TP17, TP18, TP19, AND TP20.

TM6625-623-45-C3-20

Figure 3-12. If. translator module extender, parts location

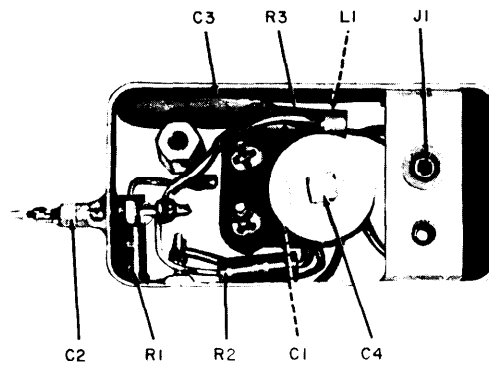

TM6625-623-45-22

Figure 3-13. If. translator dummy load, parts location.

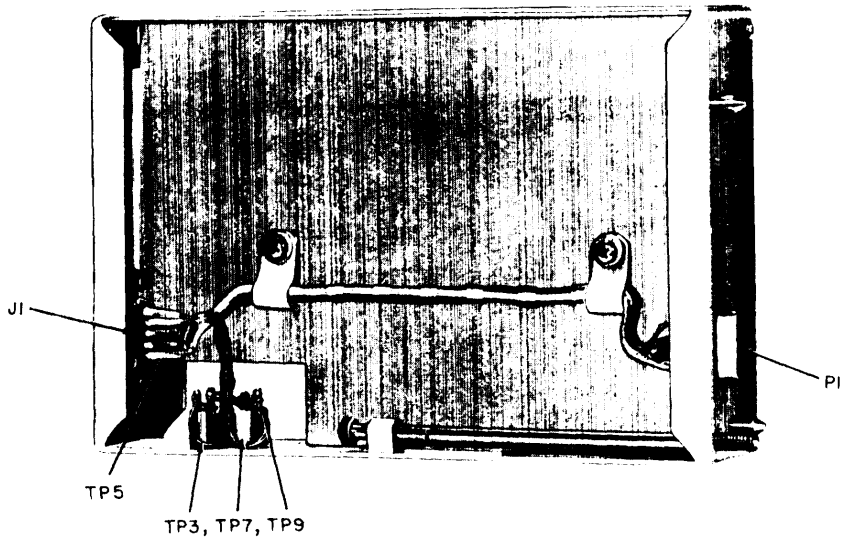

TM6625-623-45-13

Figure 3-14. Electronic control amplifier (ampl) module extender, parts location.

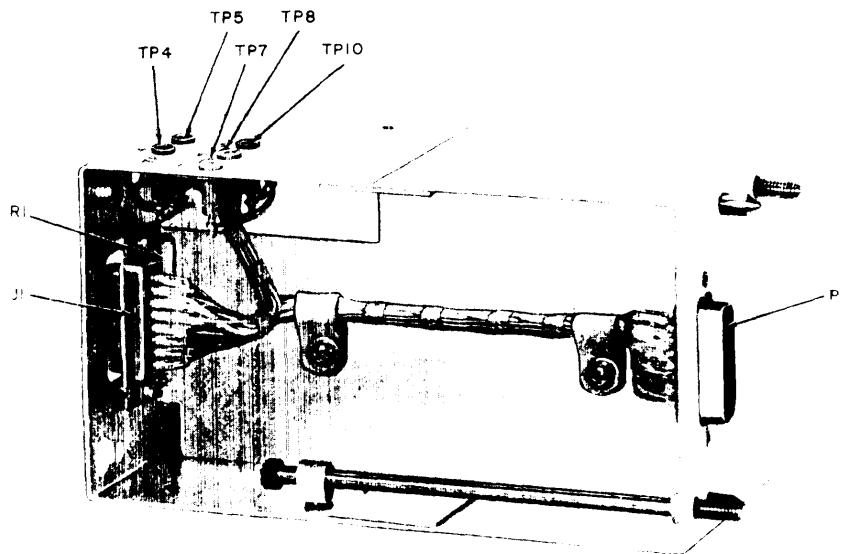

TM6625-623-45-12

Figure 3-15. Low-voltage power supply module extender, parts location.

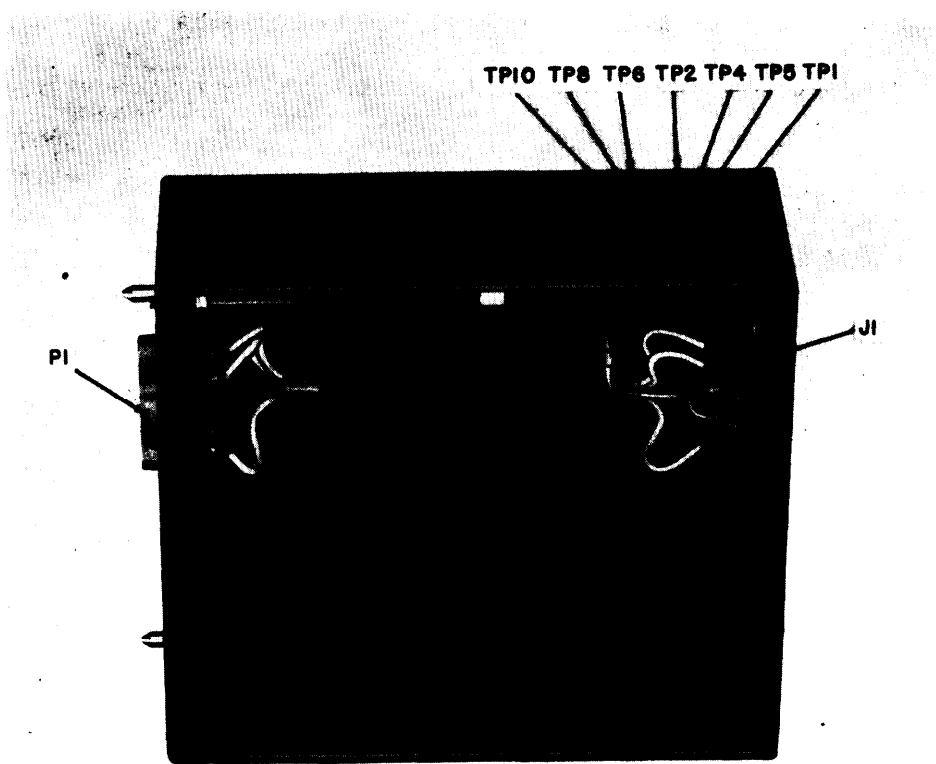

TM6625-623-45-11

Figure 3-16. Kilocycle (kc) frequency stabilizer module extender, parts location.

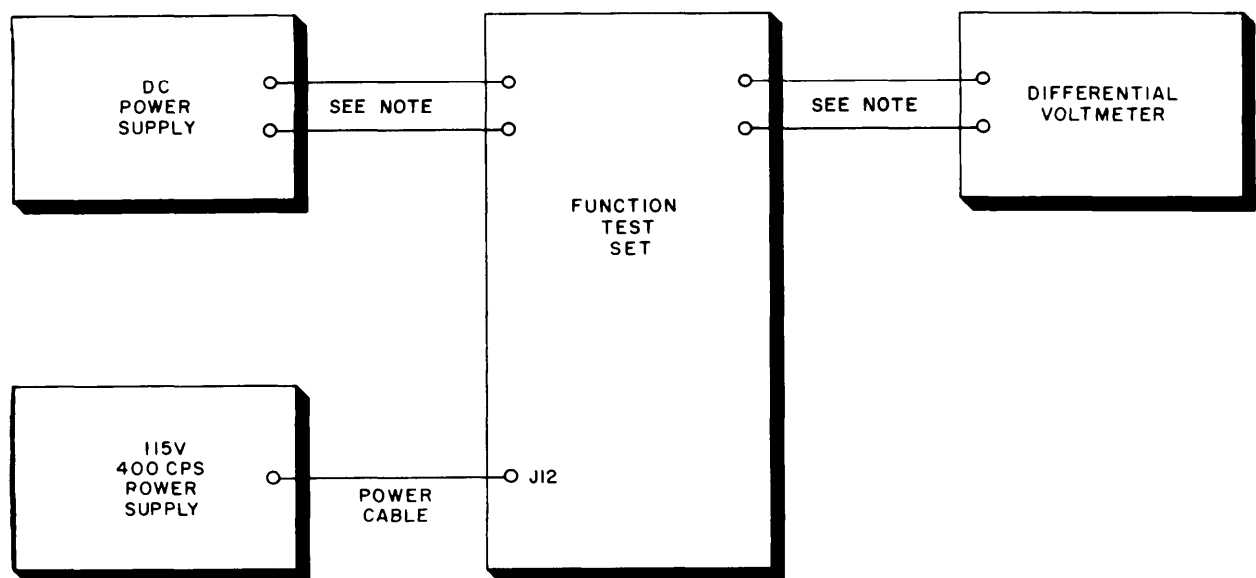

NOTE :

REFER TO CALIBRATION PROCEDURES FOR TEST CONNECTIONS

TM6625-623-45-33

Figure 3-17. Function test set calibration. connections.



## CHAPTER 4 GENERAL SUPPORT TESTING PROCEDURES

### 4-1. General

*a.* Testing procedures are prepared for use by Signal Field Maintenance Shops and Signal Service Organizations responsible for general support maintenance of signal equipment to determine the acceptability of repaired signal equipment. These procedures set forth specific requirements that repaired signal equipment *must* meet before it is returned to the using organization. Equipment that meets the minimum standards stated in the tests will furnish satisfactory operation equivalent to that of new equipment. The testing procedures may also be used as a guide to test equipment repaired by direct support maintenance personnel if the proper tools and test equipment are available. A summary of the performance standards is given in paragraph 4-6.

*b.* Comply with the instructions preceding each chart before proceeding to the chart. Perform each test in sequence. Do not vary the sequence. For each step, perform all the actions required in the *Control setting* columns; then perform each specific test procedure and verify it against its performance standard.

### 4-2. Test Equipment Required

All test equipment required to perform the testing procedures given in this chapter are listed below and are authorized under TA 11-17, Signal Field Maintenance Shops, and TA 11-100 (11-17), Allowances of Signal Corps Expendable Supplies for Signal Field Maintenance Shop.

Nomenclature	Federal stock No.	Technical manual
Multimeter ME-26B/U _____	6625-542-6407 _____	TM 11-6625-200-12.
Voltmeter, Electronic AN/USM-98 . .	6625-753-2115 _____	TM 11-6625-438-10.
Power supply PP-351/U -----	6130-565-0706 _____	TM 11-5121.

**Note:** Voltage supply must be adjustable to two-decimal place accuracy.

### 4-3. Modification Work Orders

The performance standards listed in the tests (para 4-4 and 4-5) are based on the as-

sumption that applicable modification work orders have been performed. A listing of current modification work orders will be found in DA Pam 310-4.





**4-4. Physical Tests and Inspections**

- a. *Test Equipment and Materials.* None.
- b. *Test Connections and Conditions.*
  - (1) No connections necessary.
  - (2) Remove rear cover from function test set.
- c. *Procedure.*

Step No.	Control setting		Test procedure	Performance standard
	Test equipment	Equipment under test		
1	None -----	Controls and switches may be in any position.	<p>a. Inspect case and chassis for damage or missing parts and condition of paint.</p> <p><b>Note: Touchup painting is recommended instead of refinishing whenever practical; screwheads binding posts, receptacles and other plated parts will be painted or polished with abrasives.</b></p> <p>b. Inspect all controls and assemblies for loose or missing screws, bolts, and nuts.</p> <p>c. Inspect all connectors and receptacles, fuse holders, and the meter for looseness, damage, or missing parts.</p>	<p>a. No damage evident or parts missing. External surfaces intended to be painted will not show bare metal. Panel lettering will be legible.</p> <p>b. Screws, nuts, and bolts will be tight; none missing.</p> <p>c. No loose parts or damage. No missing parts.</p>
2	None -----	Controls and switches may be in any position.	<p>a. Rotate all panel controls throughout their limits of travel.</p> <p>b. Operate all switches.</p> <p>c. Connect all cables to their respective receptacles.</p>	<p>a. Controls will rotate freely without binding or excessive looseness.</p> <p>b. Switches will operate properly.</p> <p>c. All cables will connect smoothly; no binding or forcing required.</p>
3	<p><i>MX-1292/PAQ</i></p> <p>a. Connect mercury vapor lamp.</p> <p>b. Install wide transmission filter in lamp.</p>	Controls and switches may be in any position.	Turn on mercury vapor and expose to direct rays of lamp the portion of equipment that has been repaired or disturbed.	<p><b>Note: Moisture-fungiproofing varnish glows gray-green under rays of a mercury vapor lamp.</b></p> <p>All repaired or disturbed electrical components and chassis surfaces will be covered. There must be <i>no</i> varnish on switch contacts.</p>

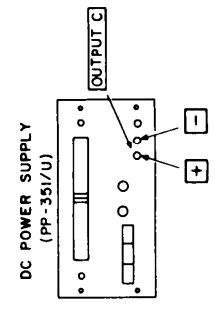
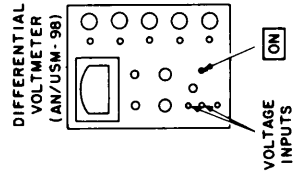
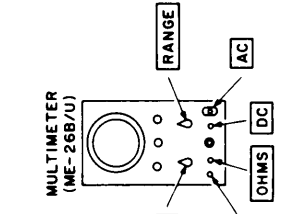
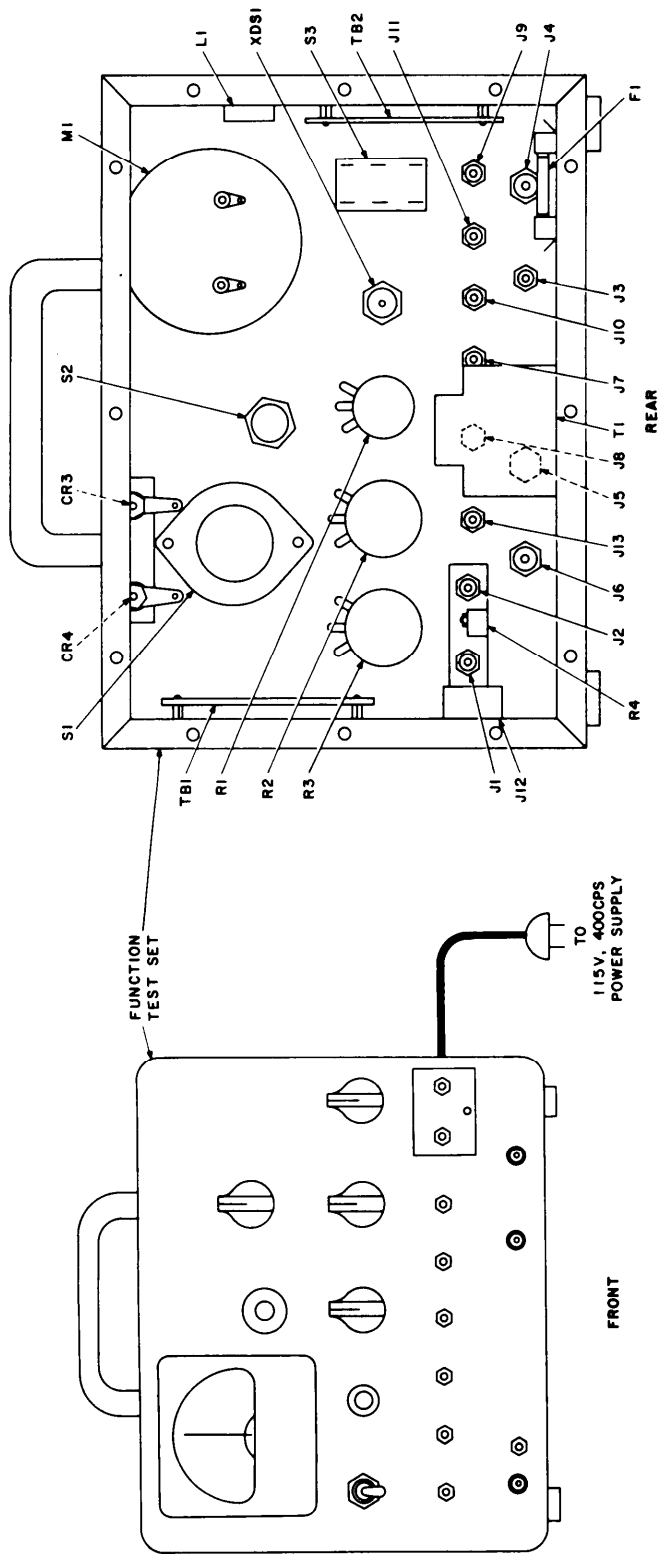

NOTE:  
 INDICATES EQUIPMENT MARKING.

TM6625-623-45-29

Figure 4-1. Voltage and resistance test connections.

**4-5. Voltage and Resistance Measurements**

*a. Test Equipment and Materials.*

- (1) **Multimeter ME-26B/U (multimeter) or equivalent.**
- (2) **Voltmeter, Electronic AN/USM-98 (differential voltmeter) or equivalent.**
- (3) **Power Supply PP-351/U (variable dc voltage supply, 0 to 20 volts, 1 milliampere (ma) maximum) or equivalent.**

*b. Test Connections and Conditions.*

- (1) **Make test connections as specified in *Test procedure* column of c below and illustrated in figure 4-1.**
- (2) **Resistance checks are made with no power applied to the function test set.**

Note: For parts location, refer to figures 2-1, 2-2, and 2-3.

*c. Procedure.*

Step No.	Control setting		Test procedure.	Performance standard
	Test equipment	Equipment under test		
1	a. FUNCTION switch: OHMS. b. RANGE switch: RX10.	FUNCTION SELECTOR switch: TGC OVERRIDE.	Measure the resistance between J2-IF TRANS jack J9 and J2-FREQ DIVIDER jack 11 with TGC & CAPTURE RANGE R3 potentiometer at clockwise and counterclockwise stop.	Circuit should measure 600 ohms $\pm 120$ with R3 at clockwise stop and 100 ohms $\pm 20$ at counterclockwise stop.
2	Same as step 1.	a. FUNCTION SELECTOR switch: TGC OVERRIDE. b. TGC & CAPTURE RANGE R3 potentiometer: clockwise stop.	Measure the resistance between J2-IF TRANS jack J9 and GRND jack J13.	Circuit should measure 100 ohms $\pm 20$ .
3	a. FUNCTION switch: OHMS. b. RANGE switch: RX1K.	a. FUNCTION SELECTOR switch: 70K-5 CAPTURE RANGE. b. TGC & CAPTURE RANGE R3 potentiometer: counterclockwise stop.	Measure the resistance between J3-KC STAB jack J8 and J2-FREQ DIVIDER jack J11.	Circuit should measure 10,000 ohms $\pm 1,500$ .
4	a. FUNCTION switch: OHMS, b. RANGE switch: RX100K.	a. FUNCTION SELECTOR switch: 70K-3 CAPTURE RANGE. b. TGC & CAPTURE RANGE R3 potentiometer: counterclockwise stop.	Measure the resistance between J1-KC STAB jack J7 and J2-FREQ DIVIDER jack J11.	Circuit should measure 470 kilohms $\pm 70$ .
5	a. FUNCTION switch: OHMS. b. RANGE switch: RX1.	a. FUNCTION SELECTOR switch: SET LEVEL.	Measure the resistance between CALIBRATE WITH 10.000V R4 jack J13 with OFF-SET. ADJUST R2 potentiometer at clockwise and counterclockwise stops.	Circuit should measure 0 ohm at clockwise stop and 50 ohms $\pm 10$ at counterclockwise stop.

step No.	Control setting		Test procedure	Performance standard
	Test equipment	Equipment under test		
6	a. FUNCTION switch: OHMS. b. RANGE switch: RX10.	Controls and switches may be in any position.	Measure the resistance between NO. 1 and NO. 2 AUDIO IN jacks J5 and J6.	Circuit should measure 164 ohms $\pm 25$ .
7	Same as step 6.	Same as step 6.	Measure the resistance between AUDIO OUT jack J4 and GRND jack J13.	Circuit should measure 82 ohms $\pm 12$ .
8	a. FUNCTION switch: OHMS. b. RANGE switch: RX1.	Same as step 6.	Measure the resistance between AUDIO OUT jack J4 and TEST POINT jack J3.	Circuit should measure 0 ohm.
9	a. FUNCTION switch: OHMS. b. RANGE switch: RX1M.	Same as step 6.	Measure the resistance from NO. 1 AUDIO IN jack J5 to GRND jack J13.	Capacitor C2 charges until resistance to ground is infinite.
10	a. FUNCTION switch: +. b. RANGE switch: 300V.	a. FUNCTION SELECTOR switch: TGC OVERRIDE. b. Ac power switch ON.	Measure the voltage to ground across the series Zener diodes CR3 and CR4.	Circuit should measure 103 volts dc $\pm 5$ .
11	a. FUNCTION switch: +. b. RANGE switch: 100V.	a. FUNCTION SELECTOR switch: TGC OVERRIDE. b. LEVEL SET R1 potentiometer: counter-clockwise stop. c. Ac power switch: ON.	Measure the voltage to ground at the center arm of R1.	Circuit should measure 75 volts dc $\pm 10$ .
12	Same as 11.	a. FUNCTION SELECTOR switch: SET LEVEL. b. Ac power switch: ON.	Adjust LEVEL SET R1 potentiometer until the FUNCTION METER of the function test set reads + 10. Measure the voltage to ground at the center arm of R1.	Circuit should measure 90 volts dc $\pm 5$ .
13	Set the differential voltmeter to measure 10 volts dc.	a. FUNCTION SELECTOR switch. 70 K-3 VFO BIAS. b. Ac power switch: ON.	Connect the differential voltmeter between the CALIBRATE WITH 10.000V R4 test points.	differential voltmeter should read 10.000 volts dc $\pm 0.001$ .

Step No.	Control setting		Test procedure	Performance standard
	Test equipment	Equipment under test		
14	Set the differential voltmeter to read 20 volts dc.	a. FUNCTION SELECTOR switch: 10KC CONTROL BIAS (+20V). b. Ac power switch: ON.	Apply a dc voltage of approximately 20 volts between J4-KC STAB jack J10 and ground. Vary the dc voltage for a null indication on the FUNCTION METER. Measure the applied dc voltage with the differential voltmeter.	Differential voltmeter should read 19.930 volts dc.
15	Set the differential voltmeter to read 18 volts.	a. FUNCTION SELECTOR switch: +18V. b. Ac power switch: ON.	Apply a dc voltage of approximately 18 volts between J2-FREQ DIVIDER Jack J11 and ground. Vary the voltage for an exact FUNCTION METER null with the X10 METER SENSITIVITY switch depressed. Measure the applied dc voltage with the differential voltmeter.	Differential voltmeter should read 18.000 volts dc $\pm 0.036$ .

**4-6. Test Data Summary**

Maintenance personnel may find it convenient to arrange the checklists in a manner similar to that below. The data included in the checklists may then be used as a check against the test results the next time the tests are performed.

**VOLTAGE AND RESISTANCE MEASUREMENTS**

Note: The numbers in the *Step No.* column below are references to the *Step No.* column in paragraph 4-5c.

Step No.	Indication
1	600 ohms $\pm 120$ at clockwise stop. 100 ohms $\pm 20$ at counterclockwise stop.

Step No.	Indication
2	100 ohms $\pm 20$ .
3	10,000 ohms $\pm 1,500$ .
4	470 kilohms $\pm 70$ .
5	0 ohm at clockwise stop. 50 ohms $\pm 10$ at counterclockwise stop.
6	164 ohms $\pm 25$ .
7	82 ohms $\pm 12$ .
8	0 ohm.
9	Capacitor C2 charges until resistance to ground is infinite.
10	103 volts dc $\pm 5$ .
11	75 volts dc $\pm 10$ .
12	90 volts dc $\pm 5$ .
13	10.000 volts dc $\pm 0.001$ .
14	19.930 volts dc.
15	18.000 volts dc $\pm 0.036$ .



#### 5-4. General Test Requirements

Depot overhauls standards consist of performance of the tests indicated in paragraphs 4-4, 4-5, and 4-6 and the following tests. The following tests consist of signal level measurements and continuity checks. Paragraphs 4-4, 4-5, and 4-6 cover tests of the TS-1956/URC (fig. 4-11), the function test set.

#### 5-5. Test of Voltage Divider TS-1954/URC (2 to 8 mc capacity divider)

(fig. 3-2 and 4-3)

- a. Set the output frequency of the AN/GRM-50 (signal generator) to 5 mc.
- b. Connect the 6-db pad between the signal generator and the ME-30A/U.
- c. Set the signal generator output for a 5 mc, .33 volt output.
- d. Connect the input terminal of the TS-1954/URC to the output of the 6-db pad and connect the ME-30A/U to the output terminal of the TS-1954/URC.
- e. ME-30A/U should indicate 0.01 volt  $\pm 10\%$  (0.009 to 0.011 volt).

#### 5-6. Test of Voltage Divider TS-1955/URC (8 to 30 mc capacity divider)

(fig. 3-3 and 4-4)

- a. Set the output frequency of the signal generator for 19 mc.
- b. Connect the 6-db pad between the signal generator and the AN/URM-145.
- c. Set the signal generator output for a 19 mc, .35 volt output.
- d. Connect the input terminal of the TS-1955/URC to the output of the 6-db pad and connect the AN/URM-145 to the output terminal of the TS-1955/URC.
- e. AN/URM-145 should indicate 0.01 volts  $\pm 0.001$ .

#### 5-7. Test of Detector, Radio Frequency DT/278/URC (Neutralizing Detector)

(fig. 3-5 and 4-6)

- a. Set the output frequency generator to 500 kc.
- b. Connect the 6-db pad between the signal generator and the ME-30A/U.
- c. Set the signal generator for a 500 kc, 1 volt output.
- d. Disconnect the ME-30A/U.
- e. Connect the DT-278/URC red lead to the common terminal of the 6-db pad and the gray lead to the positive terminal of the 6-db pad.

f. Connect the ME-26B/U between the red and gray tip jacks of the DT-278/URC (red tipjack is common). The ME-26B/URC should indicate no less than 1 volt dc.

#### 5-8. Test of Extender, Module MX-4892/URC (If Translator Module Extender)

(fig. 3-12, 3-13, 4-8 and 4-12)

- a. Set the output frequency of the signal generator to 500 kc.
- b. Connect the 6-db pad between the signal generator and the ME-30A/U; use the CG-2727/U to connect the 6-db pad to the ME-30A/U.
- c. Adjust the signal generator for an output of 0.07 volt.
- d. Disconnect the ME-30A/U from the CG-2727/U and connect the CG-2727/U to the MX-4892/URC RF LOAD BNC connector.
- e. Connect the ME-30A/U between the MX-4892/URC blue tipjack and the frame.
- f. Adjust the capacitor on the side of the MX-4892/URC to an indication on the ME-30A/U of a peak of 0.055 volt  $\pm 0.005$ .
- g. Disconnect the MX-4892/URC from test setup and test continuity of remaining circuits (fig. 4-12).

#### 5-9. Test of Dummy Load, Electrical DA-340/URC (Rf Translator Load)

(fig. 3-4 and 4-5)

- a. Connect a 6-db pad to the signal generator output.
- b. Connect the AN/URM-145 to the signal generator output with the UG-274B/U connector.
- c. Set the signal generator for a 2 MHz 3 volt output.
- d. Connect the UG-274B/U connector to the DA-340/URC connector associated with the blue tipjack using the 4 to 12 inch fabricated cable.
- e. Check that the AN/URM-145 indicates not less than 2.90 volts.
- f. Set the frequency of the signal generator to 30 mc and disconnect the DA-340/URC from the UG-274B/U.
- g. Set the signal generator output level to 3 volts.
- h. Connect the DA-340/URC to the UG-274B/U as indicated in d above.
- i. The AN/URM-145 should not indicate less than 2.2 volts.
- j. Check that resistance between J1 and P1 and between J2 and P2 is less than one (1) ohm.

**5-10. Test of Attenuator, Fixed CN-1066/ URC (Generator Load)**

(fig. 3-1 and 4-2)

*a.* Connect the ZM-4B/U between center conductors of the CN-1066/URC BNC connectors.

*b.* The ZM-4B/U shall indicate 50 ohms  $\pm 5$ ; center conductors shall not be shorted to outer conductor or case.

**5-11. Test of Test Probe No. 1**

(TM 11-6625-623-12, fig. 1-6)

*a.* Connect the XM-3/U between center conductors (tip probe to center of BNC connector).

*b.* The ZM-3/U shall indicate 100 mmf  $\pm 10$  mmf.



## APPENDIX I REFERENCES

Following is a list of applicable references available to the general support and depot repairman of Maintenance Kit, Electronic Equipment MK-722/URC:

DA Pam 310-4	Index of Technical Manuals, Technical Bulletins, Supply Manuals (Types 4, 6, 7, 8, and 9), Supply Catalogs (Type CL), Supply Bulletins, Lubrication Orders, and Modification Work Orders.
SM 11-4-5180-R08	Tool Kit, Radar and Radio Repairman TK-87/U.
TA 11-17	Signal Field Maintenance Shops.
TA 100 (11-17)	Allowances of Signal Corps Expendable Supplies for Signal Field Maintenance Shops.
TM 11-5121	Power Supply PP-351/U.
TM 11-6625-200-12	Operator and Organizational Maintenance Manual: Multimeters ME-26A/U, ME-26B/U, and ME-26C/U.
TM 11-6625-438-10	Operator's Manual: Voltmeter, Electronic AN/USM-98.
TM 11-6625-623-12	Operator and Organizational Maintenance Manual: Maintenance Kit, Electronic Equipment MK-722/URC.

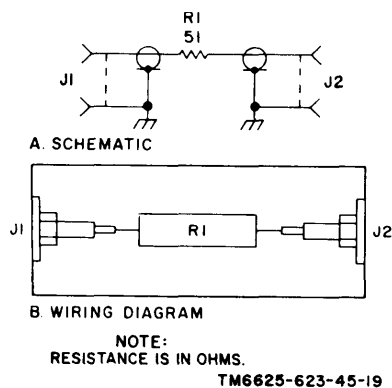

Figure 4-2. Generator load, schematic and wiring diagram.

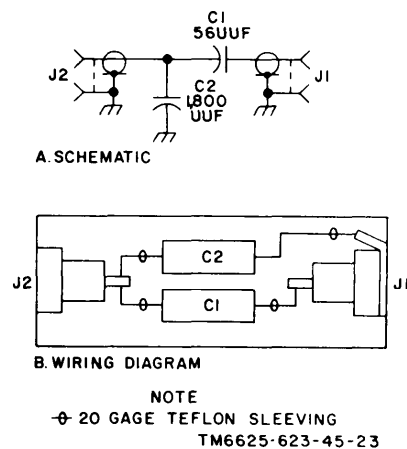

Figure 4-3. Capacity divider, 2- to 8-mc, schematic and wiring diagram.

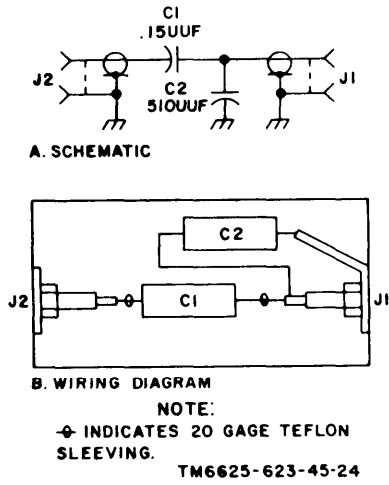

Figure 4-4. Capacity divider, 8- to 30-mc, schematic and wiring diagram.

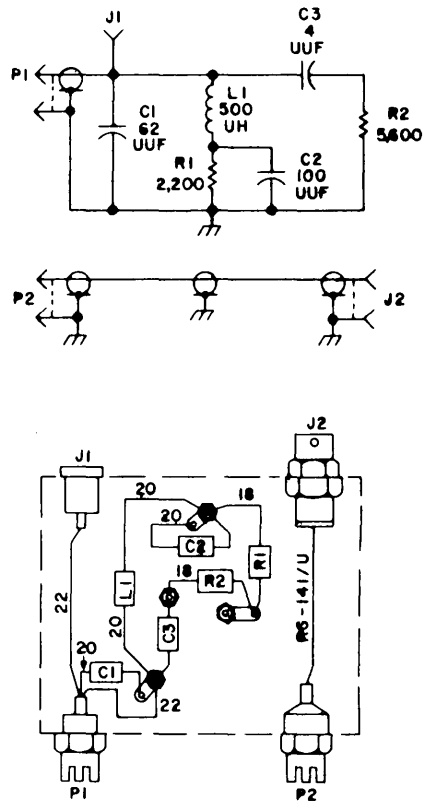

Figure 4-5. Rf translator load, schematic and wiring diagram.

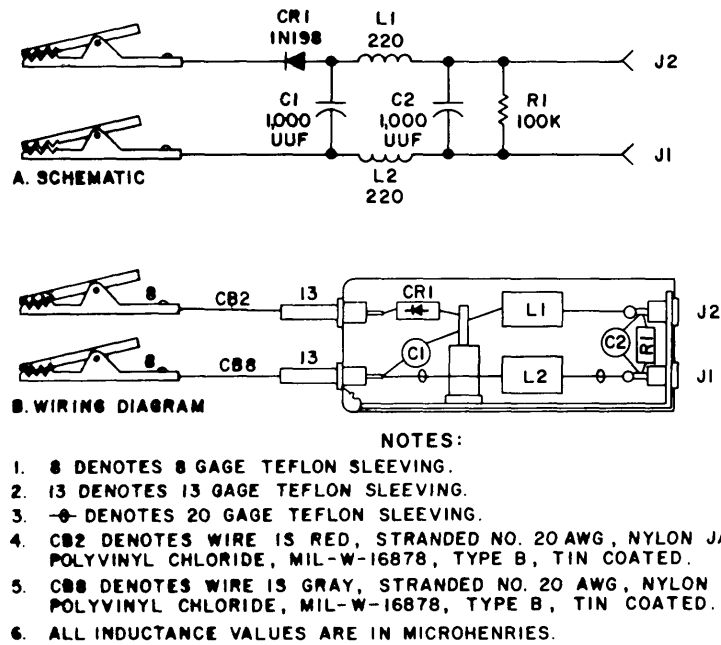

Figure 4-6. Neutralizing detector, schematic and wiring diagram.

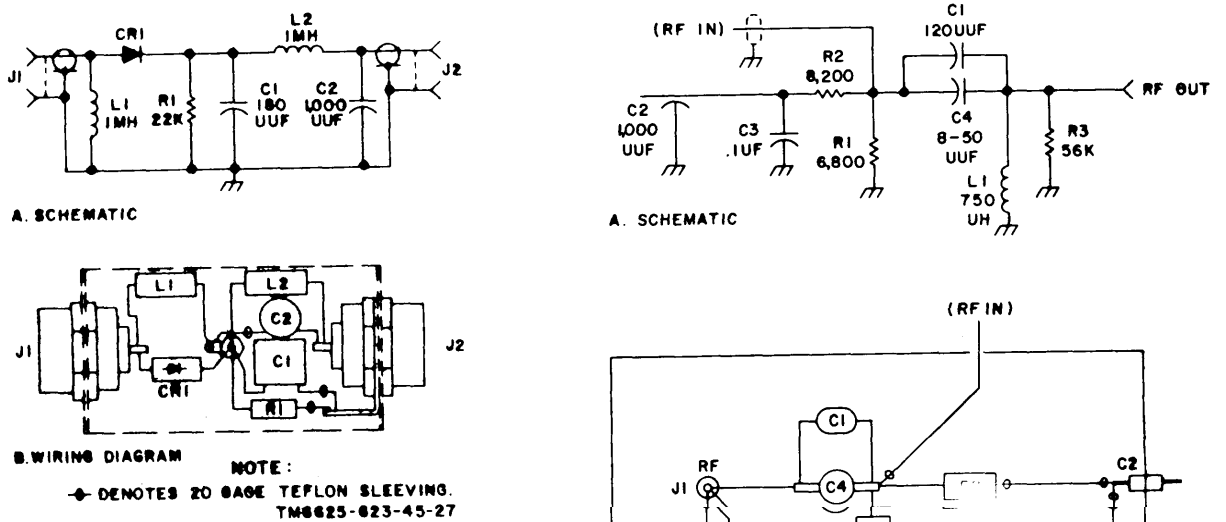

Figure 4-7. Detector, 2- to 30-mc, schematic and wiring diagram.

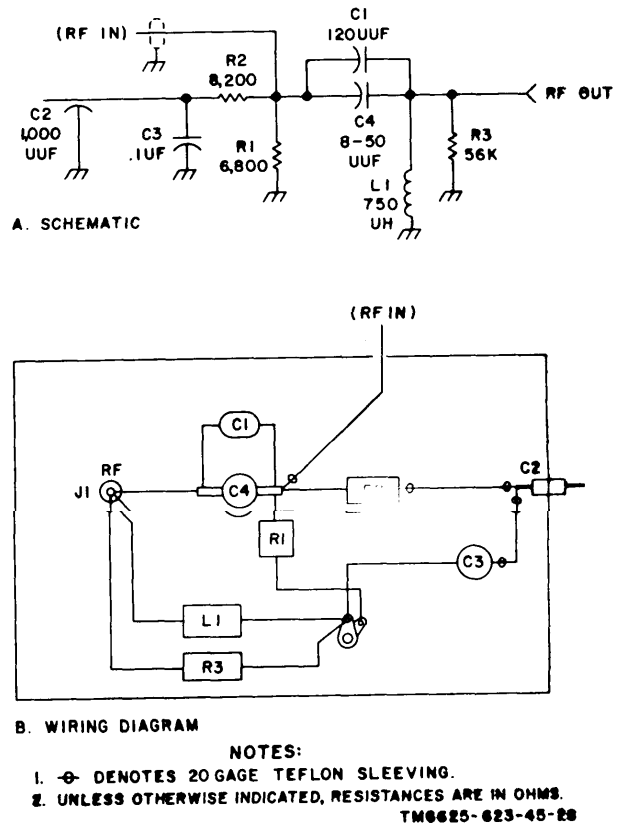
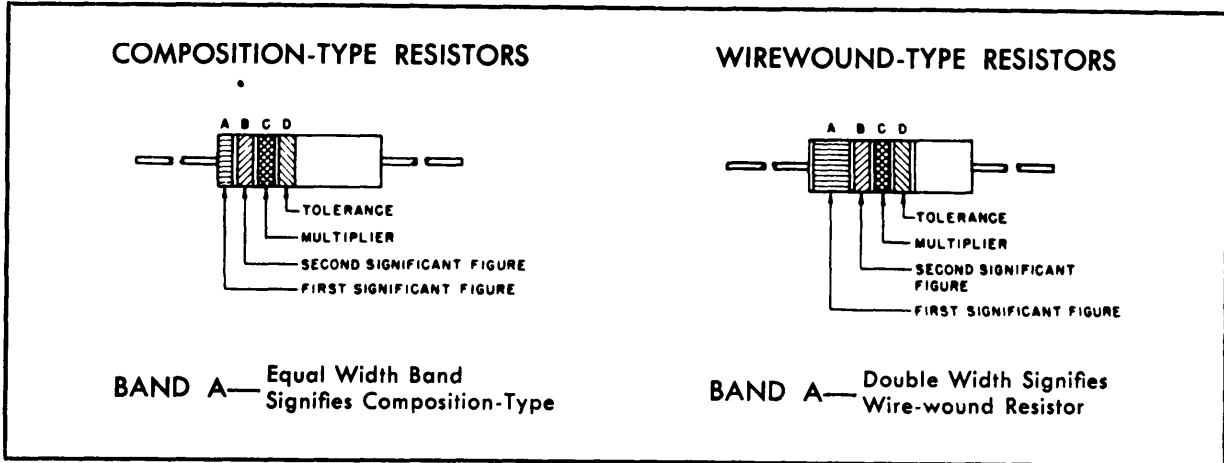

Figure 4-8. If translator dummy load, schematic and wiring diagram.

### COLOR CODE MARKING FOR MILITARY STANDARD RESISTORS



#### COLOR CODE TABLE

BAND A		BAND B		BAND C		BAND D*	
COLOR	FIRST SIGNIFICANT FIGURE	COLOR	SECOND SIGNIFICANT FIGURE	COLOR	MULTIPLIER	COLOR	RESISTANCE TOLERANCE (PERCENT)
BLACK	0	BLACK	0	BLACK	1		
BROWN	1	BROWN	1	BROWN	10		
RED	2	RED	2	RED	100		
ORANGE	3	ORANGE	3	ORANGE	1,000		
YELLOW	4	YELLOW	4	YELLOW	10,000	SILVER	± 10
GREEN	5	GREEN	5	GREEN	100,000	GOLD	± 5
BLUE	6	BLUE	6	BLUE	1,000,000		
PURPLE (VIOLET)	7	PURPLE (VIOLET)	7				
GRAY	8	GRAY	8	SILVER	0.01		
WHITE	9	WHITE	9	GOLD	0.1		

#### EXAMPLES OF COLOR CODING

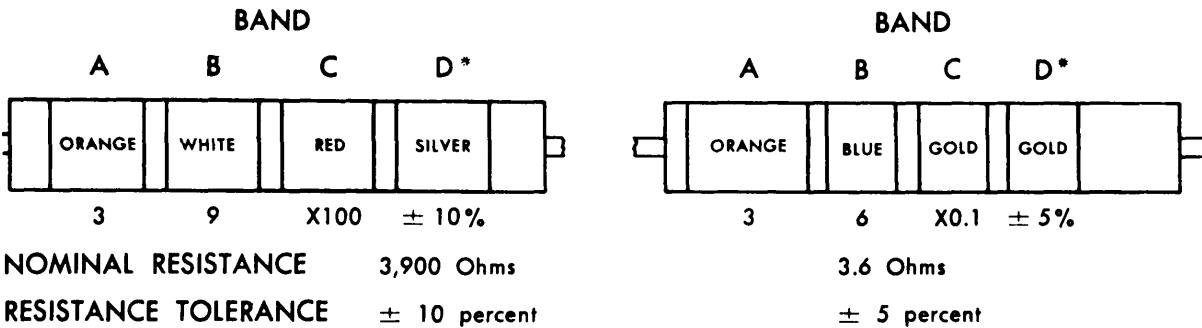

\*If Band D is omitted, the resistor tolerance is ± 20%, and the resistor is not Mil-Std.

STD-R2

Figure 4-9. Color code marking for MIL-STD resistors.

COLOR CODE MARKING FOR MILITARY STANDARD CAPACITORS

GROUP I Capacitors, Fixed, Various-Dielectrics, Styles CM, CN, CY, and CB

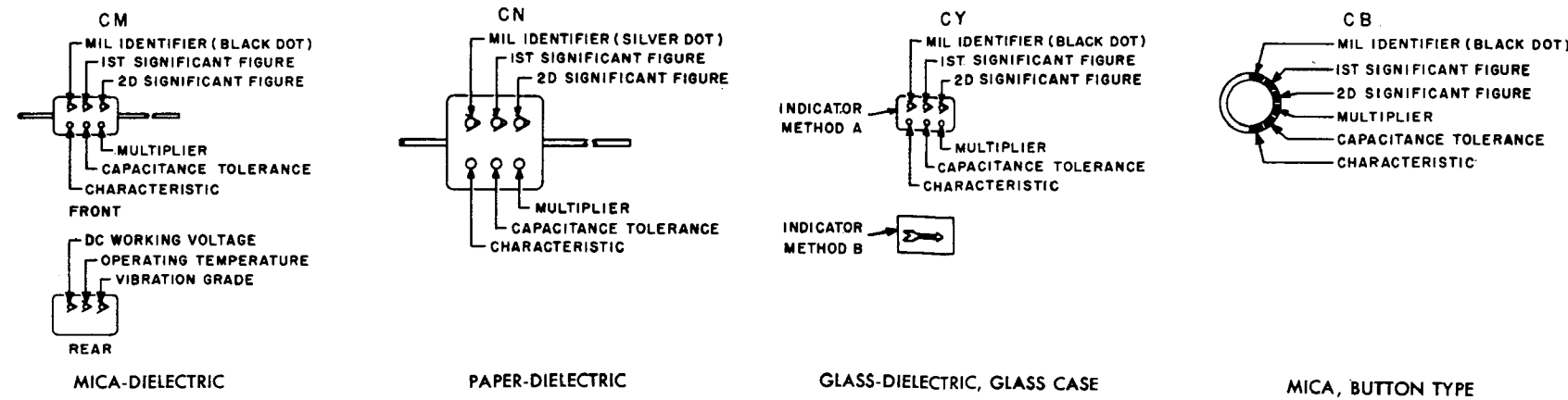

GROUP II Capacitors, Fixed Ceramic-Dielectric (General Purpose) Style CK

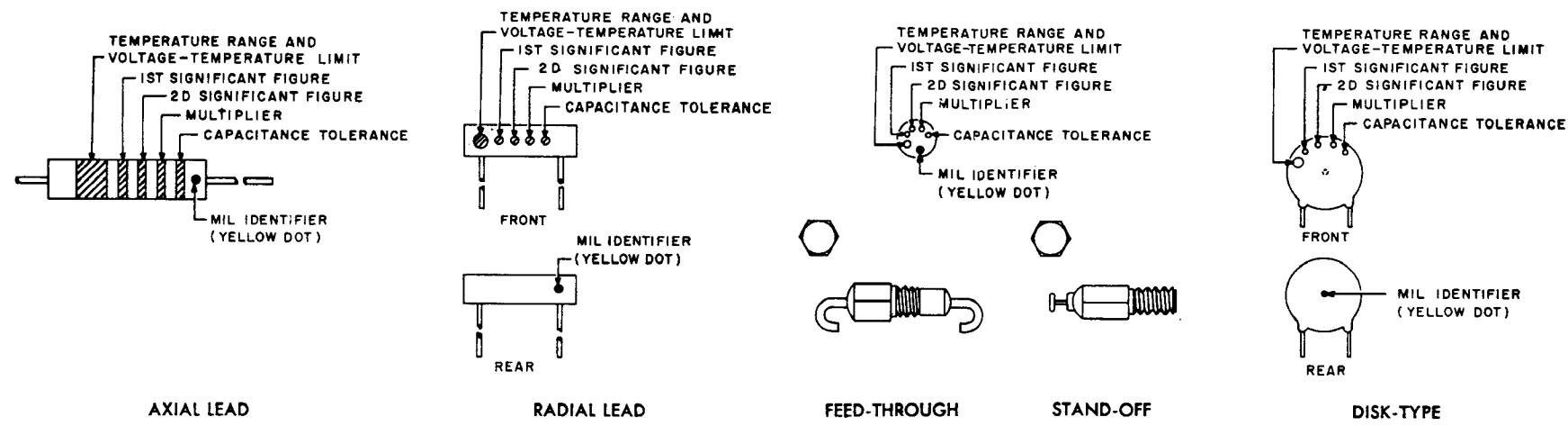

GROUP III Capacitors, Fixed, Ceramic-Dielectric (Temperature Compensating) Style CC

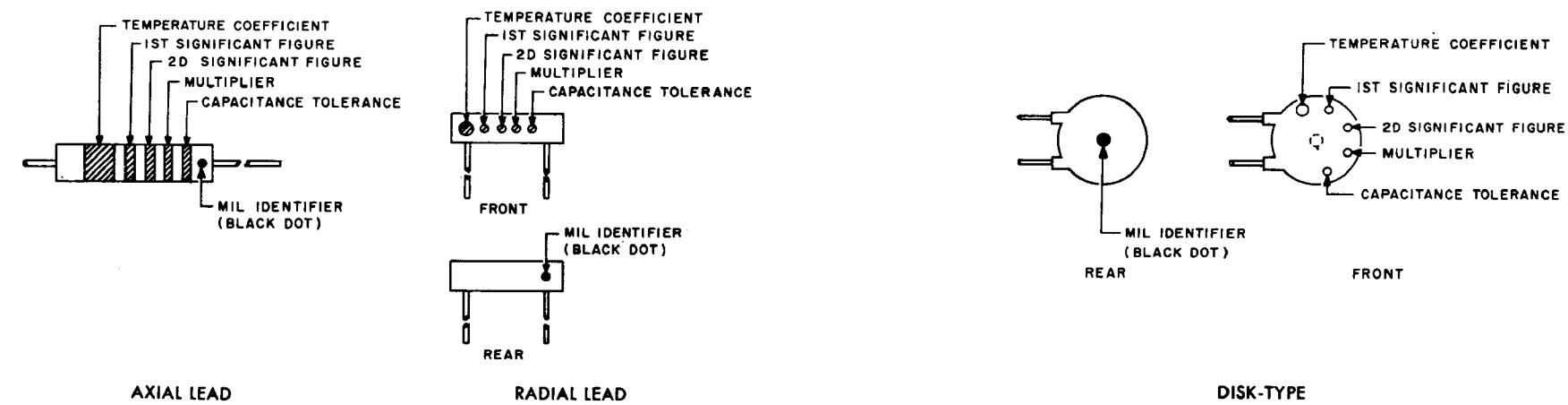

COLOR CODE TABLES

TABLE I - For use with Group I, Styles CM, CN, CY and CB

COLOR	MIL ID	1st SIG FIG	2nd SIG FIG	MULTIPLIER <sup>1</sup>	CAPACITANCE TOLERANCE				CHARACTERISTIC <sup>2</sup>				DC WORKING VOLTAGE	OPERATING TEMP. RANGE	VIBRATION GRADE
					CM	CN	CY	CB	CM	CN	CY	CB			
BLACK	CM, CY, CB	0	0	1			± 20%	± 20%		A				-55° to +70°C	10-55 cps
BROWN		1	1	10					B	E					
RED		2	2	100	± 2%		± 2%	± 2%	C		C			-55° to +85°C	
ORANGE		3	3	1,000		± 30%			D		D	300			
YELLOW		4	4	10,000					E					-55° to +125°C	10-2,000 cps
GREEN		5	5		± 5%				F			500			
BLUE		6	6											-55° to +150°C	
PURPLE (VIOLET)		7	7												
GREY		8	8												
WHITE		9	9												
GOLD				0.1			± 5%	± 5%							
SILVER	CN				± 10%	± 10%	± 10%	± 10%							

TABLE II - For use with Group II, General Purpose, Style CK

COLOR	TEMP. RANGE AND VOLTAGE - TEMP. LIMITS <sup>3</sup>	1st SIG FIG	2nd SIG FIG	MULTIPLIER <sup>1</sup>	CAPACITANCE TOLERANCE	MIL ID
BLACK		0	0	1	± 20%	
BROWN	AW	1	1	10	± 10%	
RED	AX	2	2	100		
ORANGE	BX	3	3	1,000		
YELLOW	AY	4	4	10,000		CK
GREEN	CZ	5	5			
BLUE	BV	6	6			
PURPLE (VIOLET)		7	7			
GREY		8	8			
WHITE		9	9			
GOLD						
SILVER						

TABLE III - For use with Group III, Temperature Compensating, Style CC

COLOR	TEMPERATURE COEFFICIENT <sup>4</sup>	1st SIG FIG	2nd SIG FIG	MULTIPLIER <sup>1</sup>	CAPACITANCE TOLERANCE		MIL ID
					Capacitances over 10uuf	Capacitances 10uuf or less	
BLACK	0	0	0	1		± 2.0uuf	CC
BROWN	-30	1	1	10	± 1%		
RED	-80	2	2	100	± 2%	± 0.25uuf	
ORANGE	-150	3	3	1,000			
YELLOW	-220	4	4				
GREEN	-330	5	5		± 5%	± 0.5uuf	
BLUE	-470	6	6				
PURPLE (VIOLET)	-750	7	7				
GREY		8	8	0.01			
WHITE		9	9	0.1	± 10%		
GOLD	+100					± 1.0uuf	
SILVER							

- The multiplier is the number by which the two significant (SIG) figures are multiplied to obtain the capacitance in uuf.
- Letters indicate the Characteristics designated in applicable specifications: MIL-C-5, MIL-C-91, MIL-C-11272, and MIL-C-10950 respectively.
- Letters indicate the temperature range and voltage-temperature limits designated in MIL-C-11015.
- Temperature coefficient, in parts per million per degree centigrade.

Figure 4-10. Color code marking for MIL-STD capacitors.

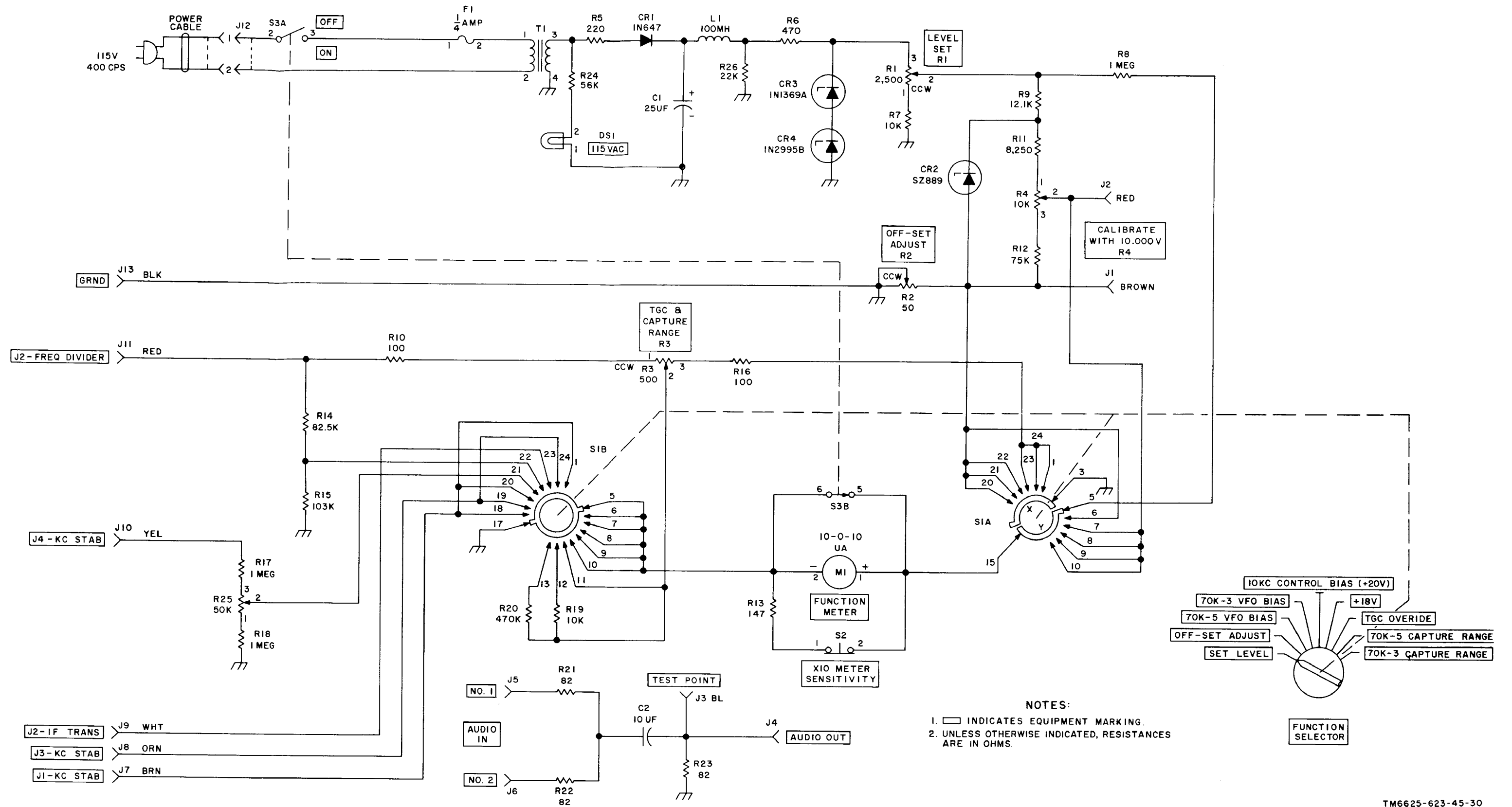

TM6625-623-45-30

Figure 4-11. Function test set, schematic diagram.

**RF TRANSLATOR MODULE EXTENDER**

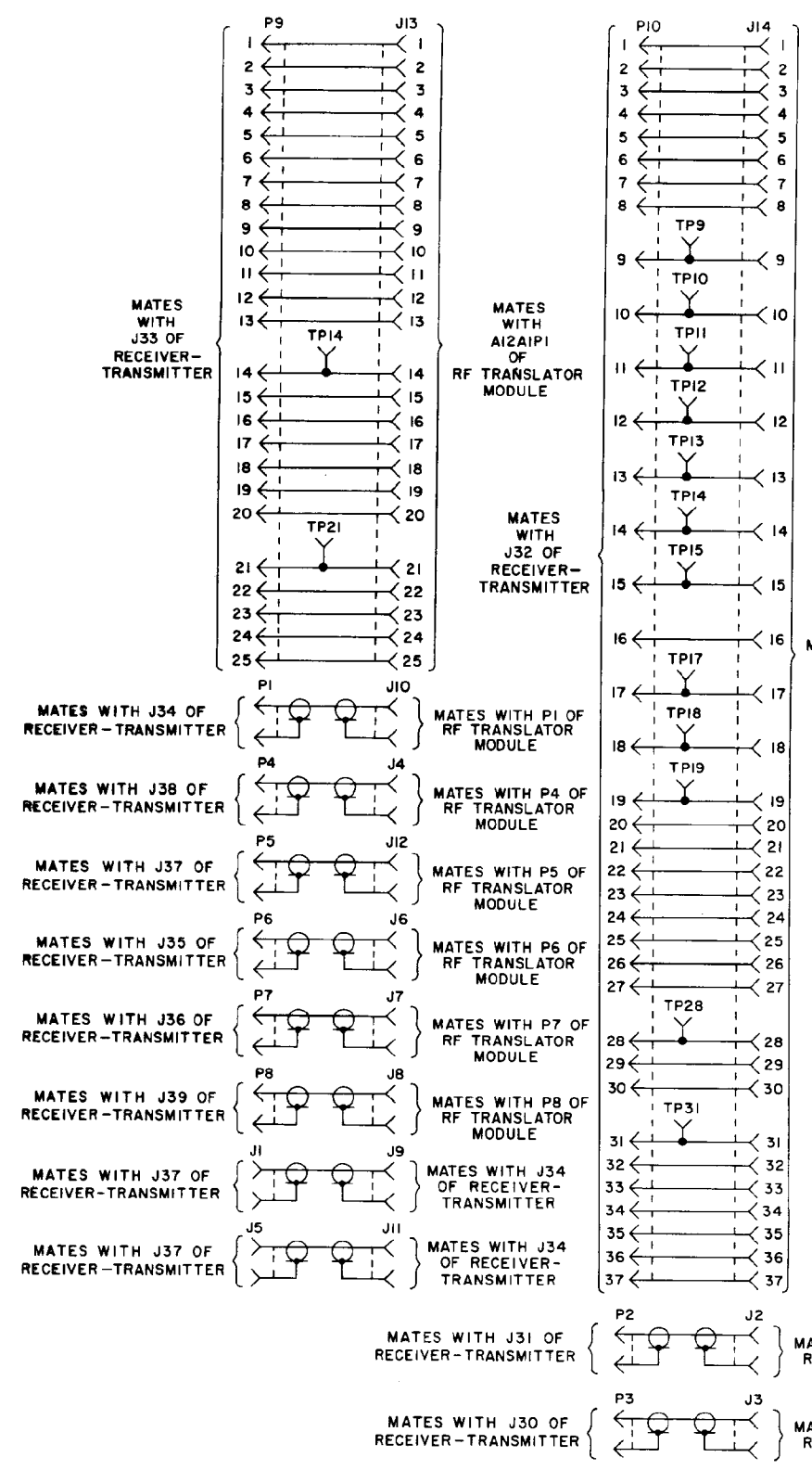

**RF OSCILLATOR MODULE EXTENDER**

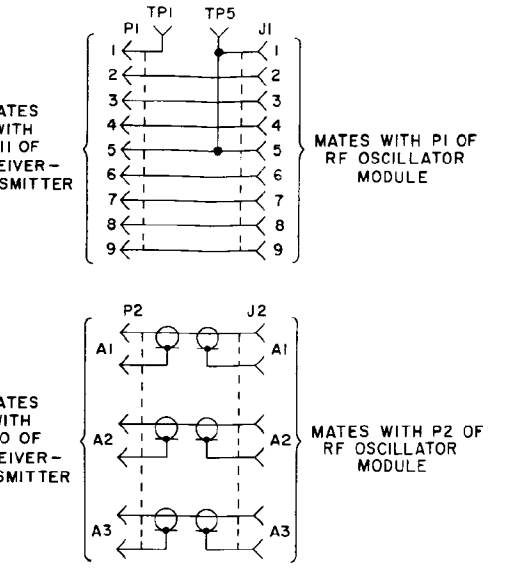

**FREQUENCY DIVIDER MODULE EXTENDER**

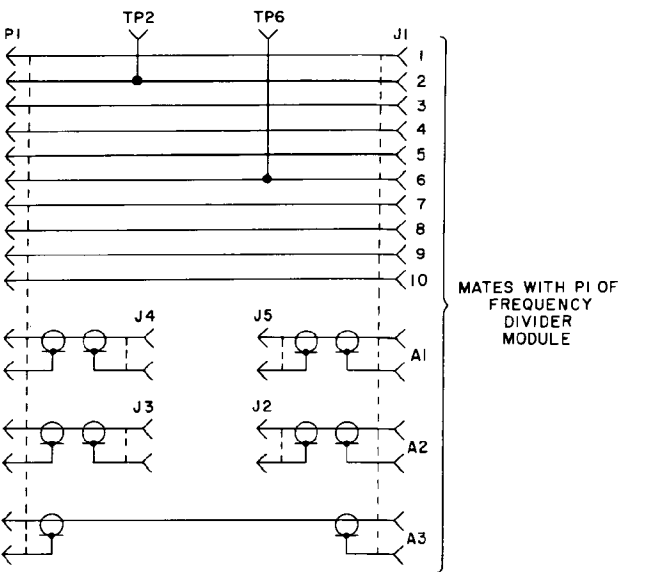

**IF TRANSLATOR MODULE EXTENDER**

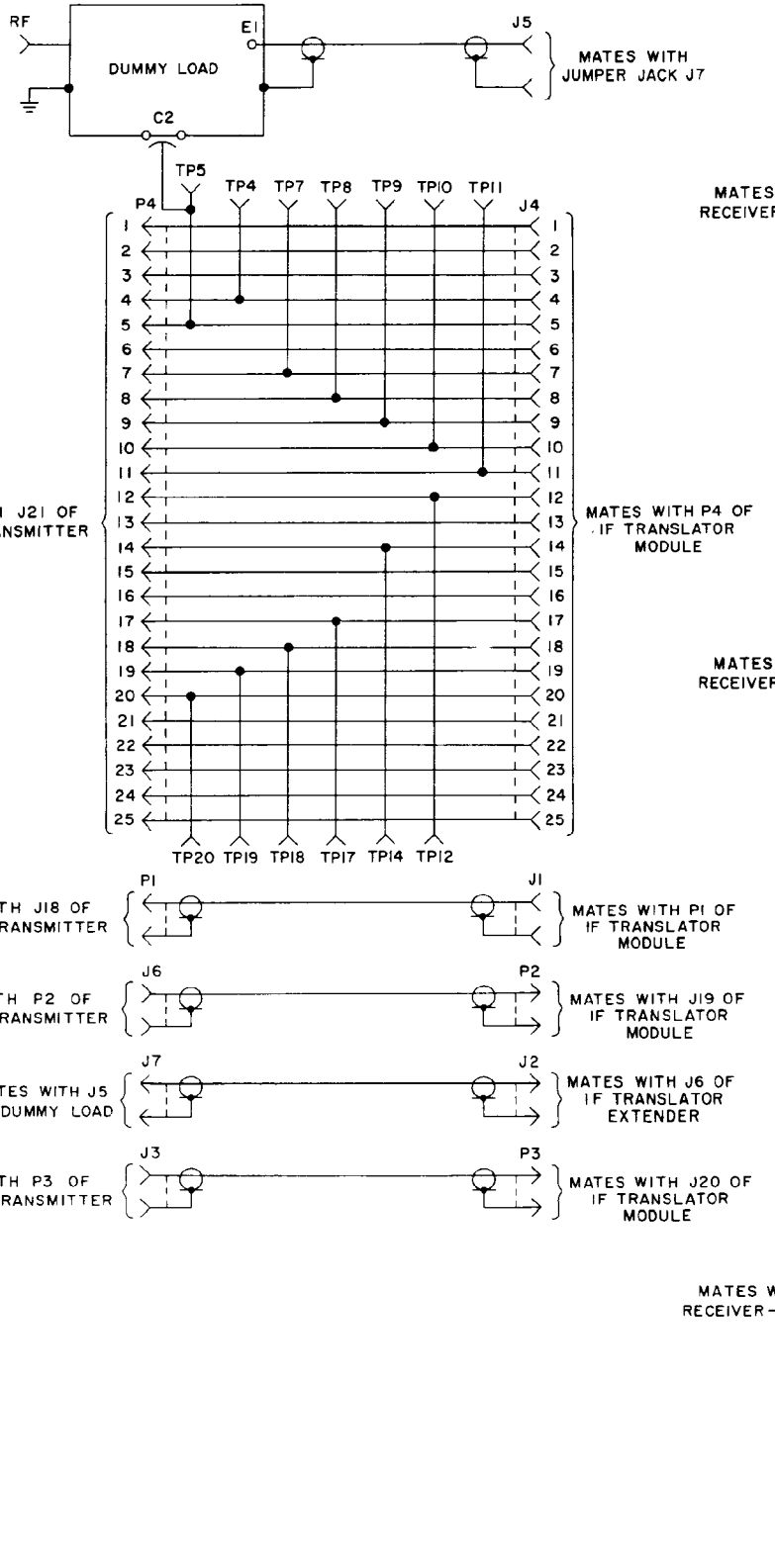

**ELECTRONIC CONTROL AMPLIFIER MODULE EXTENDER**

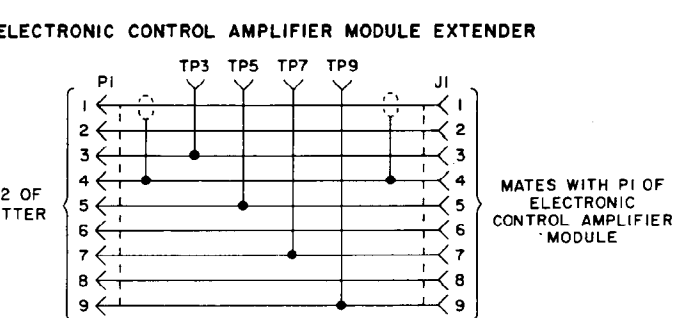

**LOW-VOLTAGE POWER SUPPLY MODULE EXTENDER**

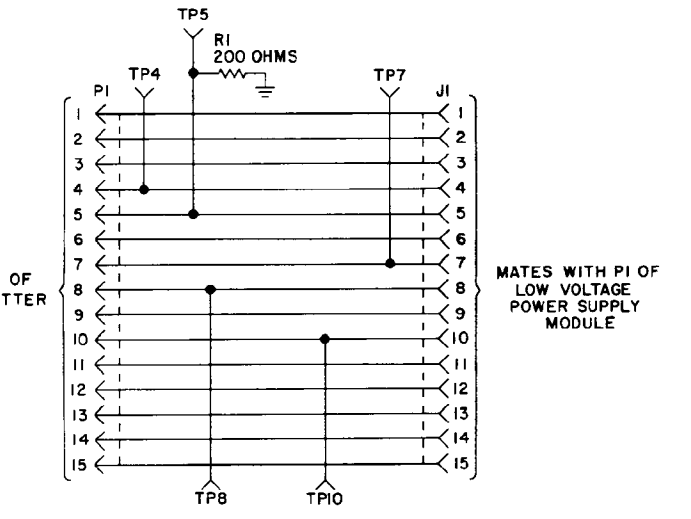

**MC FREQUENCY STABILIZER MODULE EXTENDER**

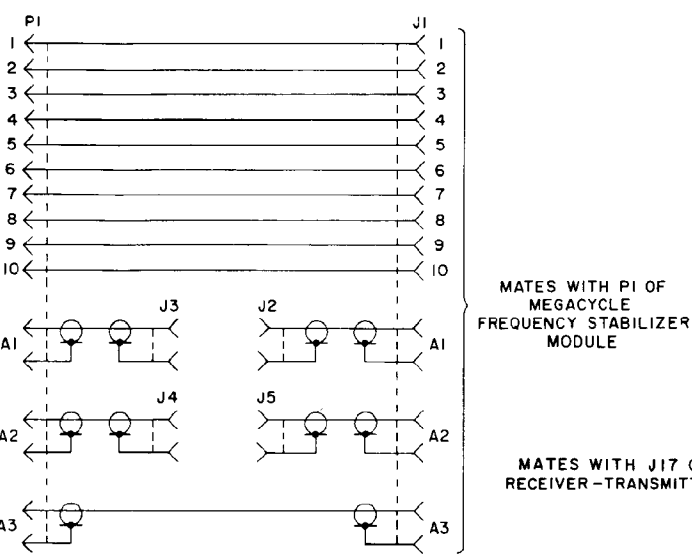

**AM/AUDIO AMPLIFIER MODULE EXTENDER**

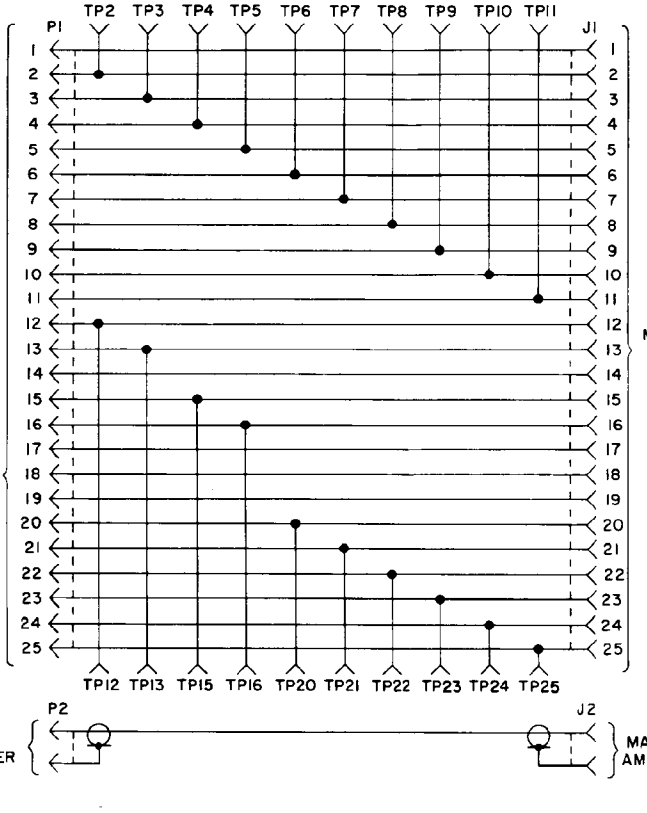

**KC FREQUENCY STABILIZER MODULE EXTENDER**

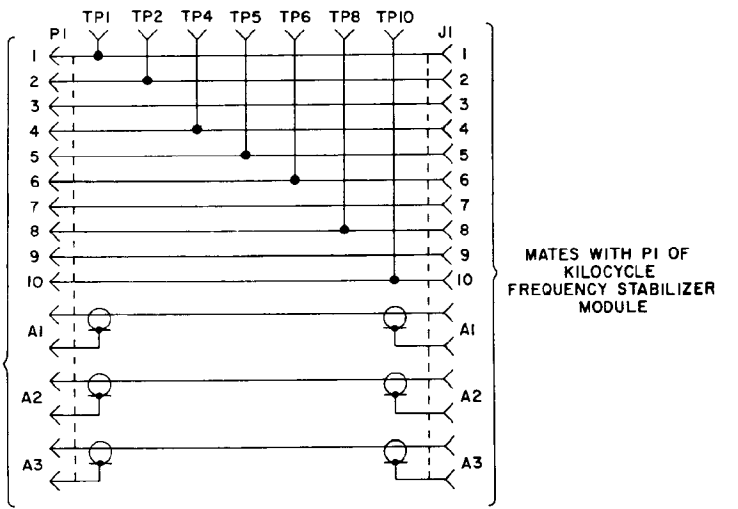
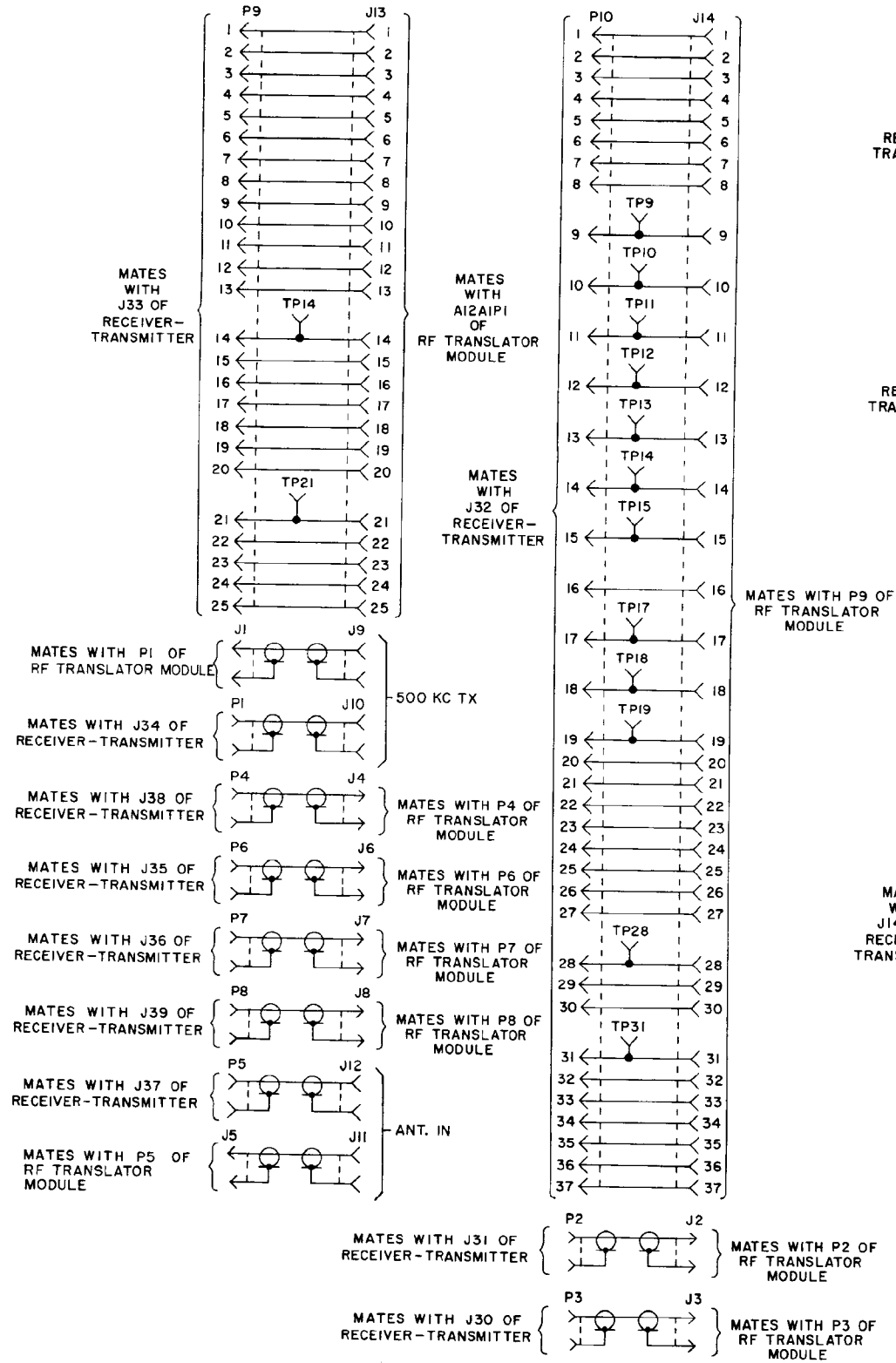
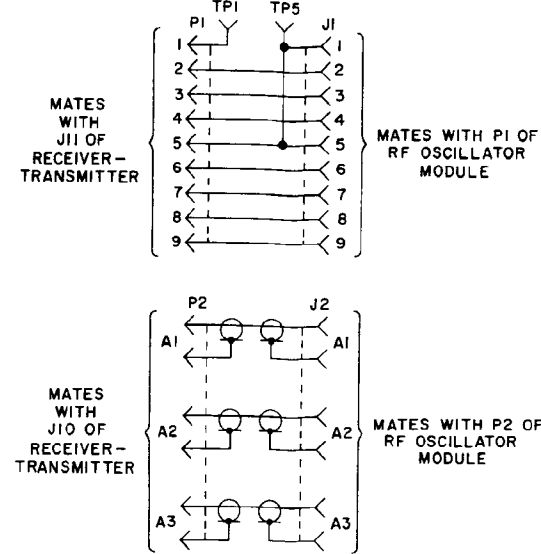

Figure 4-12. Module extenders, schematic diagrams.

RF TRANSLATOR MODULE EXTENDER



RF OSCILLATOR MODULE EXTENDER



FREQUENCY DIVIDER MODULE EXTENDER

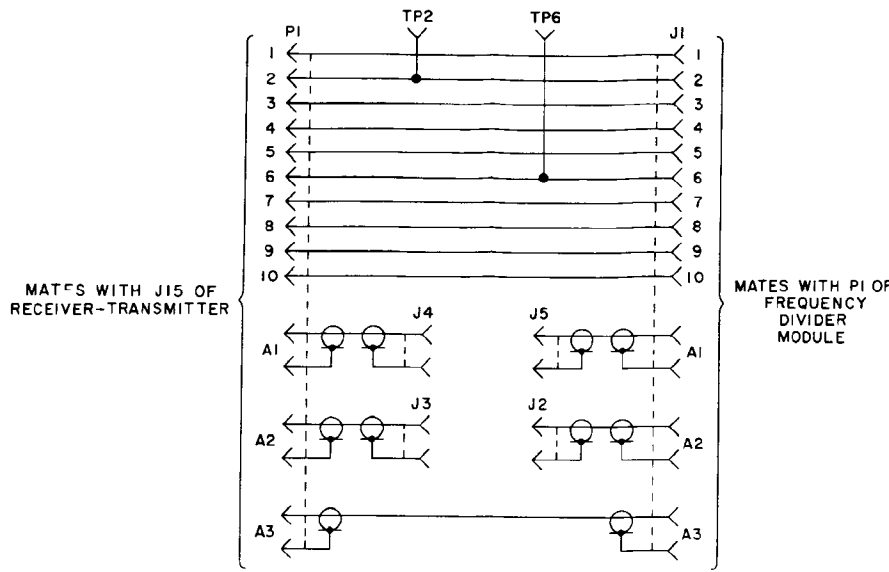

IF TRANSLATOR MODULE EXTENDER

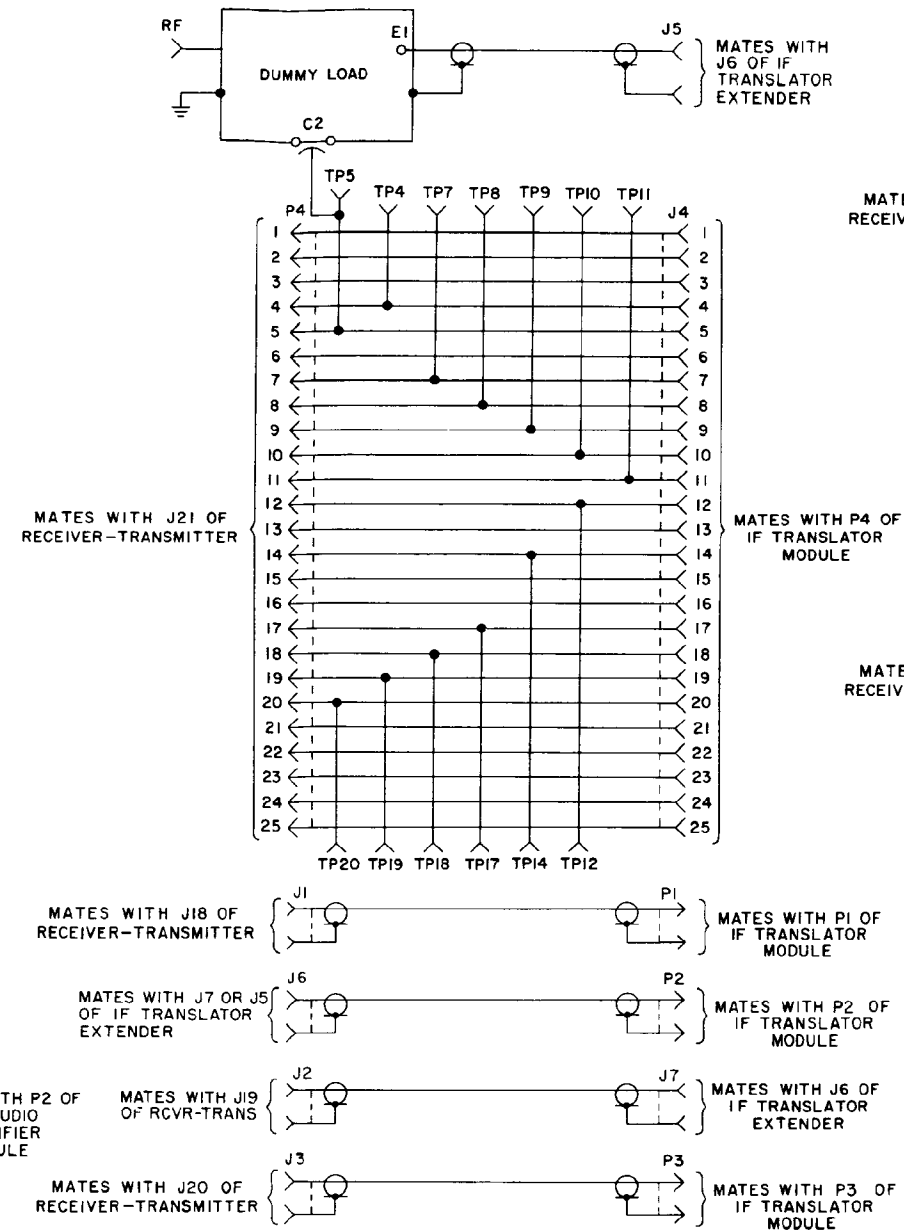

ELECTRONIC CONTROL AMPLIFIER MODULE EXTENDER

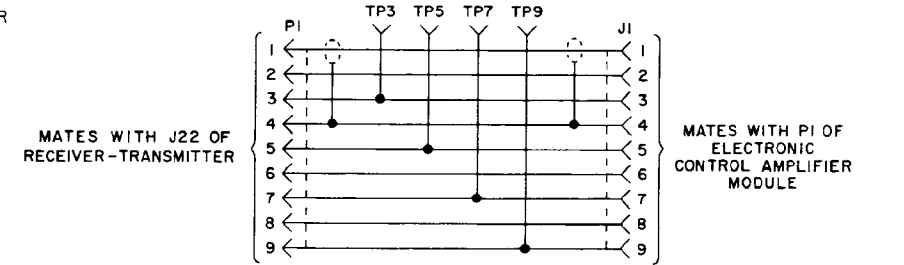

LOW-VOLTAGE POWER SUPPLY MODULE EXTENDER

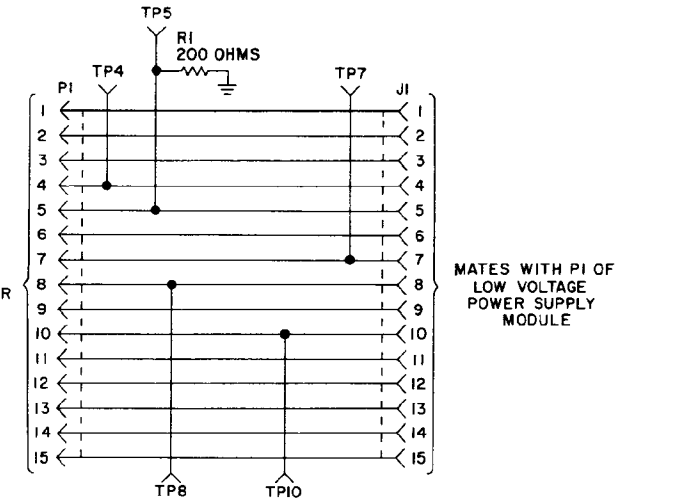

MC FREQUENCY STABILIZER MODULE EXTENDER

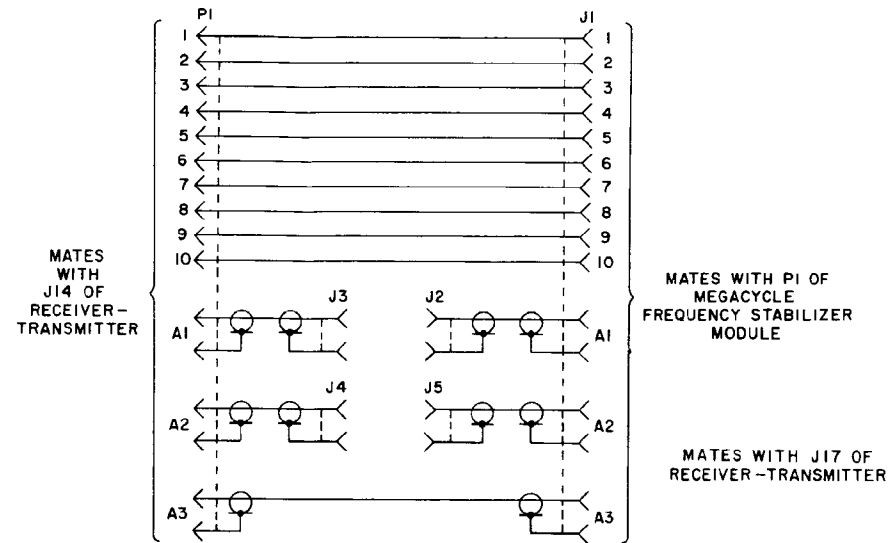

AM/AUDIO AMPLIFIER MODULE EXTENDER

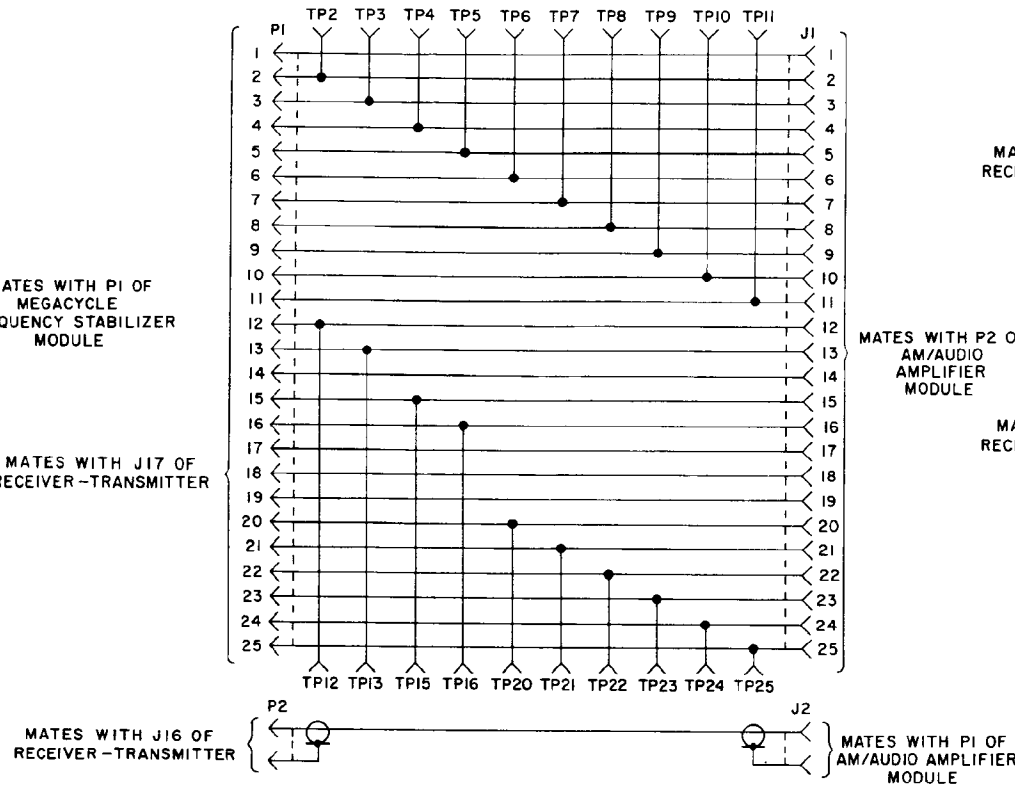

KC FREQUENCY STABILIZER MODULE EXTENDER

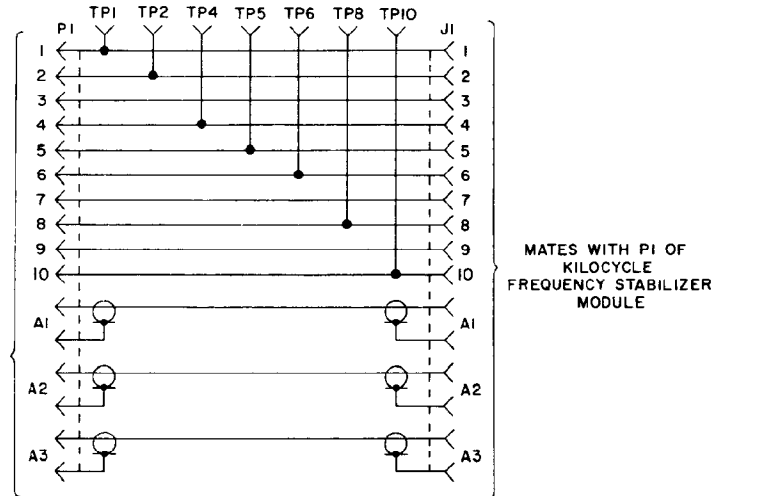



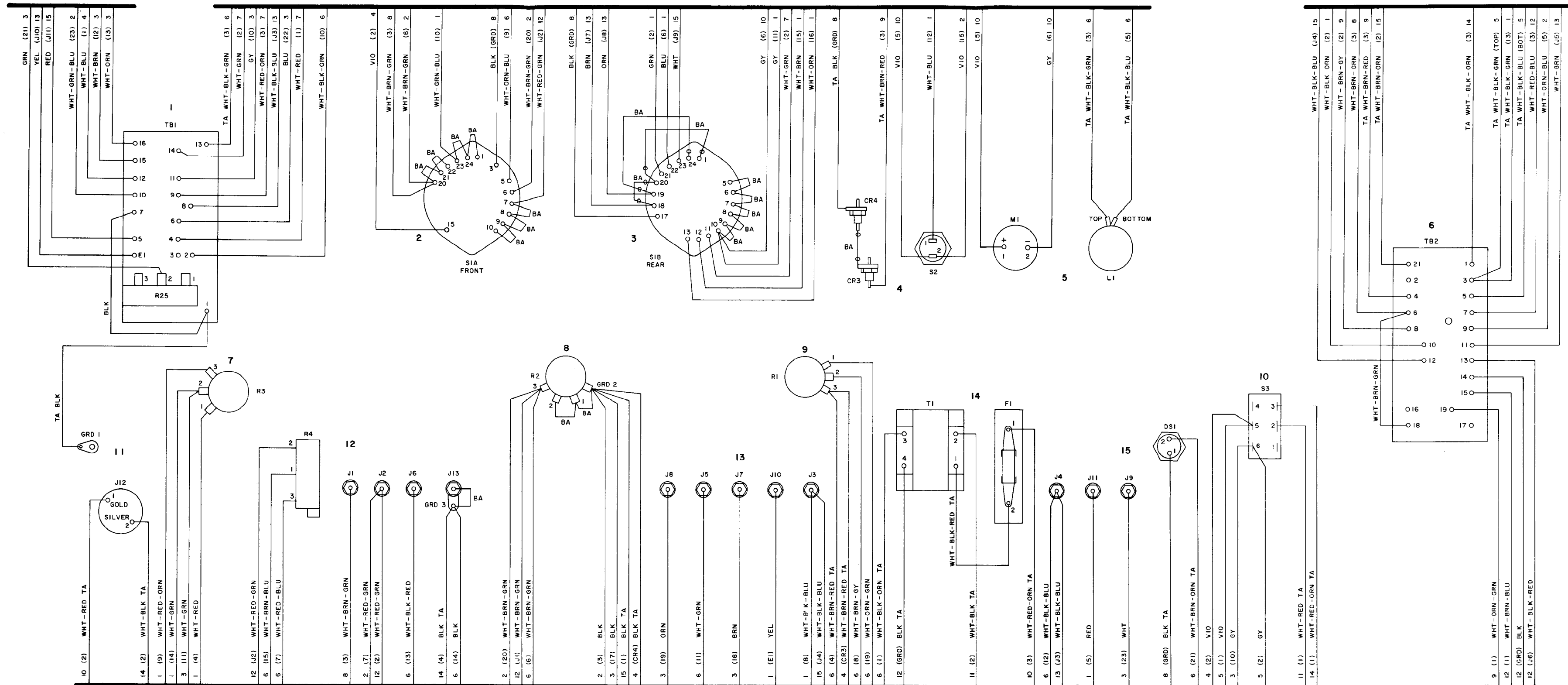

- NOTES:
1. THE SMALL NUMBER ON EACH WIRE (ADJACENT TO THE COMMON BASE LINE) CORRESPONDS TO THE LARGE NUMBER ADJACENT TO THE STATION TO WHICH THE WIRE RUNS. THE NUMBER OR LETTER IN PARENTHESES INDICATES THE TERMINAL NUMBER.
  2. TO LOCATE CONNECTING POINTS OF WIRES, USE THE METHOD ILLUSTRATED IN THE FOLLOWING EXAMPLE: TO LOCATE THE CONNECTING POINT OF A WIRE MARKED (1) 6, FIND STATION 6; THEN LOOK FOR TERMINAL 6. A WIRE TO TERMINAL 6 WILL BEAR THE SAME COLOR CODE AS THE WIRE THAT IS MARKED (1) 6.
  3. UNLESS OTHERWISE INDICATED ALL WIRES ARE HOOKUP WIRE COPPERWELD, 26 AWG, TEFLON (TFE), MIL-W-16878, TYPE E (600 VOLTS) SILVER COATED.
  4. TA INDICATES WIRE IS HOOKUP WIRE STRANDED, 22 AWG, TEFLON (TFE), MIL-W-16878, TYPE E (600 VOLTS) SILVER COATED.
  5. BA INDICATES WIRE IS BUSWIRE, ROUND TINNED, 22 AWG.
  6. ⊕ INDICATES 22 GAGE TEFLON (TFE) SLEEVING.

Figure 4-13. Functional test set, wiring diagram.

**TM 11-6625-623-45 MAINTENANCE KIT, ELECTRONIC EQUIPMENT MK-722/URC-1965**